

MEGAN: Multipurpose Energy-Efficient, Adaptable, and Low-Cost Wireless Sensor Node for the Internet of Things

Sudip Misra, *Senior Member, IEEE*, Sanku Kumar Roy, *Graduate Student Member, IEEE*, Arijit Roy, *Student Member, IEEE*, Mohammad S. Obaidat, *Fellow, IEEE*, and Avantika Jha

Abstract— In this paper, we present the design of a new sensor node, named *Multipurpose EnerGy-efficient Adaptable low-cost sensor Node (MEGAN)*, with all the desired features such as reconfigurability, flexibility, energy-efficiency, and low-cost required to build the Internet of Things (IoT). Apart from the ability to interface a maximum of 32 different sensors and actuators, MEGAN allows a user to choose the desired communication module, depending on the required range of communication. We design a novel power management circuit to extend the lifetime of the resource-constrained sensor node. Additionally, it has an integrated recharging circuit on board, which can use the energy harvested from any unregulated energy source. MEGAN combats a major drawback of application-specific sensor nodes, because of the integration of switches and a programming port. The flexibility of MEGAN, with respect to the integration of any sensor or actuator, makes it a multipurpose adaptable sensor node. The analysis of the lifetime, received signal strength indicator, packet delivery ratio, adaptability, and reliability of MEGAN under different operating conditions establish the energy efficiency and superiority of its hardware design.

Index Terms—Energy-efficient, Internet of Things (IoT), Low-cost, Multi-functional, Reconfigurable, Sensor node architecture, Wireless Sensor Network (WSN), Wireless sensor node

I. INTRODUCTION

IOT is an ever-growing network of physical devices embedded with sensors, actuators, and wireless connectivity to communicate and share their information among themselves [1], [2]. On the other hand, Wireless Sensor Networking (WSN) is a promising technology for monitoring and controlling the physical world using sensing/actuating, communicating, and processing components. In the present era of IoT, systems tend to become increasingly interconnected. The increased demand can be catered only by building WSNs among the devices to be interconnected [3], [4]. The most fundamental unit of WSN is a sensor node. The general architecture of a sensor node is depicted in Fig. 1. Sensor nodes

have their constraints in terms of energy usage, processing capability, and memory usage. A node is typically powered by batteries. As the stored charge of the batteries used in the node is lost with time, the node gets isolated from the network. To solve the problem, many energy harvesting technologies are adapted in WSN to recharge the batteries [5], [6]. However, the replacement or re-charging of batteries integrated into the nodes becomes a difficult task in the absence of any energy harvesting resource or due to the deployment of a node in adverse environmental conditions. Therefore, power consumption becomes a crucial issue in the design and development of a node, and consequently, in WSNs. So, a node must operate for long periods on a tight energy budget.

The application of IoT is in diverse areas such as agriculture, poultry and farming, smart city, and health care, where a sensor node must support heterogeneous sensors/actuators, and varying types of wireless connectivity. Existing nodes are application-specific, which limits interfacing different types and numbers of sensors, actuators, and wireless modules. Besides, there exists the restriction of programming and flexibility.

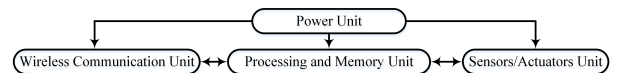

Fig. 1. Wireless sensor node architecture

Most of the existing solution approaches related to the design of a sensor node focused on energy harvesting [5], [6], and application-specific purpose [7], [8]. Sudevalayam *et al.* [5] reviewed existing energy-harvested nodes to recharge batteries to strengthen the lifetime of the nodes. On the other hand, towards energy saving of resource-constrained nodes, in the state-of-the-art, researchers [8], [9] mainly focused on hardware design, duty cycle, and routing approaches. Specifically, Somov *et al.* [8] designed a wireless gas sensor node, where the authors proposed a sensing circuit to optimize the power consumption of the gas sensing circuit. However, the power consumption of the sensing circuit in the active mode is the same as that in the sleep mode affecting the lifetime of the node. Also, inherently, there is lack of power management of other sub-components of a node, which increases the power consumption of an entire node.

On the other hand, Sen *et al.* [7] proposed design of nodes for monitoring the health condition of a building,

S. Misra and S. K. Roy are with the Department of Computer Science and Engineering, Indian Institute of Technology, Kharagpur, 721302, India (email: smisra@sit.iitkgp.ac.in and sankukumarroy@gmail.com).

A. Roy is with the Advanced Technology Development Centre, Indian Institute of Technology, Kharagpur, 721302, India (email: arijitroy@iitkgp.ac.in).

M. S. Obaidat is with the ECE Department, Nazarbayev University, Astana, Kazakhstan, KASIT, University of Jordan, Amman, Jordan, and University of Science and Technology Beijing (USTB), Beijing, China (email: msobaidat@gmail.com; m.s.obaidat@ieee.org).

A. Jha is with the Department of Electronics and Communication Engineering, National Institute of Technology Patna, 800005, India.

while detecting vibration, temperature, and humidity inside the building's walls. To identify these parameters, the authors used accelerometer, temperature, and humidity sensors, and ZigBee protocol based wireless transceiver XBee, which are equipped with the printed circuit board (PCB) of the node. The node was explicitly developed for structural health monitoring, which limits its adaptability and usability in different applications of IoT. Similarly, the proposed node by Somov *et al.* [8] is specially designed for detecting hazardous gases.

Existing works did not address the provision of circuitry-level power management of separate units of a node, which is highly required to efficiently manage the power consumption of different units in the various operational states, i.e., sleep, active, and idle. As an example, in the case of building structural health monitoring, it is not possible to get any energy harvested resource to recharge a battery. Also, deployment in such kind of applications is highly time-consuming, and there is no provision to replace a battery after deployment of nodes inside the wall. There is a requirement of an energy-efficient node to operate for longtime. In other cases, the proposed nodes are application-specific, which limits the interfacing of different types and numbers of sensors, actuators, and wireless modules. These requirements make the node impractical to survive in diverse applications of IoT. Therefore, there is a requirement of energy-efficient and adaptable sensor node to serve multiple applications of IoT.

A. Contribution

To address the issues mentioned above, we propose a novel hardware design of a wireless sensor node, which has the capability of consuming low-energy and providing more flexibility, while supporting multiple functionalities. In brief, the *contributions* in this paper are presented as follows:

- We design an energy-efficient, adaptable, and low-cost wireless sensor node to support diverse applications of IoT.
- We propose a novel power management circuit to manage and optimize the power consumption of every subsection of the node in different states of operation. Additionally, we present a design of an on-board recharging circuit for energy harvesting from any unregulated energy source.
- To support the diverse applications of IoT, we efficiently design the hardware of the node for interfacing multiple numbers and different types of sensors, actuators, and wireless communication modules.
- To show the effectiveness of the designed node, MEGAN, we evaluate the hardware-based performance of the node with respect to parameters such as current consumption, lifetime, received signal strength, packet delivery ratio, reliability, and data validation of sensory information.

II. RELATED WORKS

In this section, we discuss the existing works related to the design of a wireless sensor node towards energy-efficiency and applicability.

1) *Energy-efficient Sensor Node*: In recent years, researchers proposed different approaches such as efficient hardware design and duty-cycling to enhance the lifetime of the node [8]–[13]. Yan *et al.* [10] proposed an energy-aware sensor node. In the proposed design, the authors used ultra low-power consuming MSP430F149 microcontroller and AMS1117-3.3 voltage regulator to minimize the power consumption of the node. In addition, the node controls the power consumption of a set of sensors in the sleep/active mode and manages the transmission power setting. In the software section, the authors proposed an algorithm to estimate the lowest possible output power scheme. Similarly, Somov *et al.* [8] designed an energy-efficient wireless gas sensor node, where they proposed an intelligent approach for power saving in the sensing unit of the node. In place of the Wheatstone bridge sensing circuit, the authors used a single sensor in a voltage divider circuit to reduce the power consumption of the sensing circuit. The authors showed a significant reduction of power consumption of the node compared to the existing approaches. However, the power consumption of the sensing circuit is always the same in the active/sleep mode, which negatively affects the lifetime of the node. Moreover, the authors only focused on the power consumption of the sensing unit.

Kumar *et al.* [11] proposed an energy-efficient and smart wireless sensor node based on the IEEE 1451 standard. To reduce the power consumption of the node, the authors used electrochemical and semiconductor sensors. Further, a heating cycle is used to prevent unnecessary energy consumption at the sensing unit of the node. Likewise, Catarinucci *et al.* [12] proposed an architecture of power saving wireless sensor node, while considering two radio frequency (RF) antennas. One of these antennas is used for transmitting data, but it is normally in the sleep mode. Another antenna is dedicatedly used for detecting the RF signal, which is sent towards the node. Accordingly, the node decides the activation and information transmission time of the first RF antenna. Consequently, the node minimizes the power consumption when the data transmission is not required.

On the other hand, Alhalafi *et al.* [9] proposed a task-based sensing scheme (gTBS) to enhance the lifetime of deployed sensor nodes as well as the entire WSN. The proposed gTBS is the combination of power adaptation with a sleep and wake-up technique. Likewise, Bellasi *et al.* [13] proposed an algorithm that minimizes both the amount of transmitted data and the complexity of the algorithms, which are used for data compression to achieve the long lifetime of a sensor node.

2) *Application-specific Sensor Node*: Several works are also proposed in the context of designing sensor nodes to serve specific applications [7], [8], [11], [14]. Sen *et al.* [7] proposed the design of a sensor node to detect vibration, temperature, and humidity for monitoring the structure of a building, while considering accelerometer, temperature, and humidity sensors, and ZigBee protocol. The node limits its adaptability and usability in different applications of IoT, apart from structural health monitoring. Likewise, Monacos *et al.* [14] designed a wireless sensor node for autonomous monitoring and alert generation in remote environments. In the proposed design, the integrated components in the node are Global Positioning Sys-

tem, temperature sensor, accelerometer, and radio transceiver for taking location, determining temperature, and measuring of velocity and position, respectively.

On the other hand, the proposed node by Somov *et al.* [8] is specially designed for detecting hazardous gases. They used a planar catalytic sensor, microcontroller, and ZigBee transceiver for the detection of hazardous gases, processing, and wireless communication. Similarly, the proposed node by Kumar *et al.* [11] is designed to sense temperature, humidity, CO, and CO₂ to serve comfort sensing application. The authors used seacom SIM20 module for wireless communication. All these sensors and the communication module are attached to the PCB.

Synthesis: We synthesize that there exists a research lacuna in the design of a sensor node to meet the requirement of energy-efficiency and adaptability to support multiple applications of IoT. The existing works related to energy-efficiency did not focus on circuitry-level power management of different units of a sensor node (i.e., sensor and wireless transceiver), which is highly needed to efficiently manage the power consumption of these units in the various operational states, i.e., sleep, active, and idle. On the other hand, there is a restriction of interfacing multiple sensors, actuators, and wireless modules based on the application's requirements. In this paper, we propose the design of an energy-efficient, adaptable, and low-cost sensor node for serving multiple applications of IoT. It is worth to note that this work is filed in Indian patent [15].

III. MEGAN ARCHITECTURE

The architecture of a typical wireless sensor node is shown in Fig. 1. The detailed functional block diagram of MEGAN is shown in Fig. 2. The proposed node consists of all necessary components, which help to make it energy-efficient and adaptable. A novel power management circuit is introduced to control the power supply of different units to extend the lifetime of the node. Also, the node is designed in such a way that a user can access all the GPIO pins, including the used pins for default components, to interface different types of sensors, actuators, and wireless communication protocols to serve different applications. A detailed description of each constituent part are:

1) *Sensing and Actuating Unit:* The sensing unit senses different physical parameters and transfers them to the processing unit. The actuating unit execute the instructions given in response to the sensed data. The availability of 32 GPIO pins in MEGAN is one of its significant features, which helps to interface multiple sensors and actuators to the node. MEGAN offers the *unique* flexibility of connecting various sensors and actuators that are compatible with different peripheral interfacing communication protocols such as Digital, Serial Peripheral Interface (SPI), Inter-Integrated Circuit (I2C), Analog to Digital Converter (ADC), and Universal Asynchronous Receiver Transmitter (UART).

2) *Processing Unit:* The processing unit is responsible for all the localized processing of the raw sensor data that are received from the sensing unit and the wireless communication unit. ATmega324PA is used as the processing unit of MEGAN. The ATmega324PA microcontroller is a low-power, high performance, and reduced instruction set computer (RISC)-based

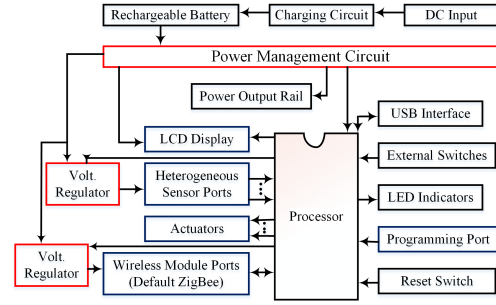

Fig. 2. Functional block diagram of MEGAN

processor. Also, the processor has a lot of features such as 32 GPIO pins, ADC, I2C, UART, SPI, Timer/Counter, Pulse Width Modulation, Joint Test Action Group, Flash memory, Static Random-Access Memory, and Electrically Erasable Programmable Read-Only Memory (EEPROM). All of these features are essential to design a multipurpose energy-efficient and adaptable wireless sensor node. Besides, the processor has two UART channels, which are required to make a separate channel for communication unit and Universal Serial Bus (USB) port. Consequently, the processing chip can be reprogrammed to meet the changing user-specific requirements.

3) *Memory Unit:* The memory unit used in the design of the sensor node is an integral part of the processing chip. The memory unit of MEGAN is composed of three units, *viz.*, *Flash memory, Fuse bit, and EEPROM.* The flash memory (32 KB) stores the executable files written by the programmer, to serve the applications. The fuse bit is used to configure the processor with respect to the hardware clock frequency, the boot reset vector, and watchdog timer. EEPROM (1 KB) is temporarily used to store the sensed data.

4) *Power Control Unit:* The power control unit manages the power supply of entire node. The onboard power supply unit consists of rechargeable batteries that are integrated at the rear of the sensor node. A recharging circuit integrated on the sensor node allows charging of the rechargeable batteries by supplying power through the DC connector. The detailed power management circuitry is presented in Section IV-A.

5) *Communication Unit:* The communication unit consists of a transceiver responsible for the reception and transmission of signals to and from the sensor nodes. MEGAN offers the rare flexibility of choice in the selection of the wireless communication module to be used. MEGAN is also compatible with various communication protocols such as *Bluetooth, ZigBee, General Packet Radio Service (GPRS), Radio Frequency Identification (RFID), Wi-Fi, and GSM.*

IV. CIRCUIT DESIGN

In this section, we discuss the hardware design of the proposed sensor node, MEGAN, while presenting the efficient power supply and management circuitry, and adaptable and flexible design.

1) *DC-DC Step-Down Converter:* Figs. IV shows DC-DC step-down converter, while converting the input DC source to a constant 5 Volts. In this section, we use standard 2.1 mm DC Barrel jack to connect standard DC power adapter/energy

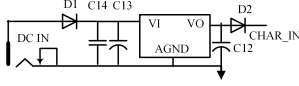

Fig. 3. DC-DC step down converter

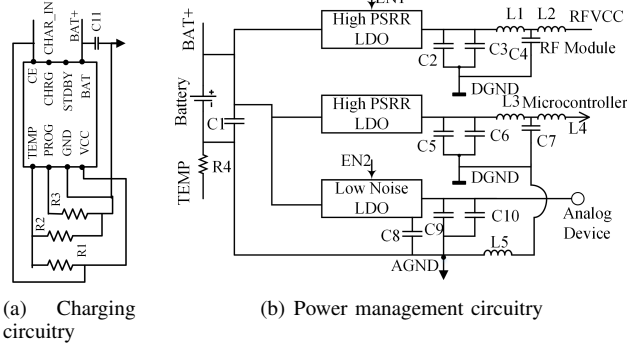

Fig. 4. Efficient power supply and management circuitry of MEGAN

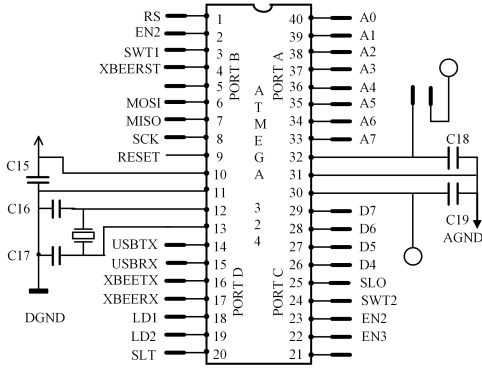

Fig. 5. Processor unit of MEGAN

harvesting resource to recharge the battery. To convert DC-DC, we use 7805 voltage regulator. On the other hand, a schottky diode (IN5808) is used to protect the circuit. The output of the converter is connected to the input of the charging circuit.

A. Efficient Power Supply and Management (EPSM)

In this section, we discuss the EPSM circuit that efficiently manages the power supply of different sub-sections of MEGAN. Additionally, there is a provision of battery recharging using DC power adapter/energy harvesting resource. The EPSM circuit is shown in Fig. 4.

1) *Charging Circuit*: Fig. 4(a) presents the charging circuit used to charge the integrated rechargeable batteries on MEGAN, while protecting the overcharging and heating of the battery in the node. In the charging circuit, we use TP4056 linear charger integrated circuit (IC).

2) *Power management circuit (PMC)*: Fig. 4(b) shows a novel PMC, which controls the power supply of the wireless module and sensors of the node in the sleep, active, and idle modes. In the power section, PMC provides three different power channels for RF module, microcontroller, and sensor/actuator. We use high power supply rejection ratio (PSRR)

low-dropout (LDO) linear regulator, TPS71933 and low noise LDO, TPS78833. The power supply of the processor unit is always in the ON state, but the power supply of other units is controlled by the processor to enhance the lifetime of the node. Also, we separate digital ground (DGND) from analog ground (AGND) using inductor for reduction of the signal noise in the node.

3) *Power Rail*: MEGAN's exquisite design provides the user to a power rail, which consists of an array of four sets of DGND, 3.3 volts for analog device, 3.3 volts for processor, and AGND pins, to provide supply and ground to the connected sensors and actuators.

B. Adaptable and Flexible Circuit Design

In this section, we present the adaptable and flexible circuit design of MEGAN. We use the term "adaptability" to characterize a node in the sense that no port is dedicated for any specific sensor/actuator/wireless module, and any port can be used for any task. We mainly focus on the hardware design of the node. We assume that user will change the corresponding firmware. Towards the objectives, we discuss different components of MEGAN, as shown in Fig. 6.

1) *Processor*: Fig. 5 shows the processor unit of MEGAN and its related circuit connections on board. Apart from the sensors, actuators, and communication modules, we attach an external clock that generates 20 MHz clock frequency, as shown in Fig. 5. In an AVR-based architecture chip, we can use both internal as well as external reference for ADC operation using a jumper. The processor consists of 4 ports, viz., PORT A, PORT B, PORT C, and PORT D. In the design, all 32 GPIO pins are open for the user to connect multiple sensor, actuator, and wireless modules.

2) *LEDs and switches*: Fig. 6(a) shows two LEDs and two switches integrated on the board that can be optionally connected with the use of jumpers. The LEDs shown in Fig. 6(a) are extremely useful to show the current state of operation of the node. The multi-functionality of MEGAN lies in exploiting these switches to configure the node to change its identity and functionality at any point of its operation.

3) *Reset Circuits*: Fig. 6(b) shows the integrated reset circuitry, which is activated by the use of a push button switch on board MEGAN.

4) *Programmer and USB ports*: Fig. 6(c) depicts the schematic of the programming port that is integrated onboard MEGAN, which gives it the unique feature of configuring itself and again to meet the changing user requirements. The USB port shown in Fig. 6(d) is useful while analyzing the node performance characteristics such as its current profile, lifetime, and also in the visualization of received and transmitted data during the experiments conducted by us. These experiments are described in Section V.

5) *LCD port*: An LCD port is shown in Fig. 6(e) and is useful in debugging and inquiring the status of the sensor node. The LCD port utilizes only 4 out of the 32 GPIO pins of the processor, as it operates in the 4 bit mode to reduce the number of pins engaged in interfacing an LCD unit. However, there is a provision to plug out the LCD display from the female header

TABLE I
COMPARISON OF MEGAN WITH OTHERS

Sensor node	MEGAN	Kumar <i>et al.</i> [11]	MICA2DOT [16]	BT node Rev3 [17]
Processor	ATmega324PA	ATmega88	ATmega128L	ATmega128L
Comm. module	Supports: ZigBee, Bluetooth, GPRS, NFC, Wi-Fi, RFID, GSM, and 3G	Simcom SIM20	CC1000 radio transceiver	Bluetooth and Chipcon radio
Charging ckt	Protection and charging circuit	NA	NA	NA
Integrated sensors	NA	Temperature, CO, CO ₂ and Humidity	Temperature and battery monitor	NA
GPIO pins	32	No GPIO pin open for user	18 solder-less expansion pins	2 modular extension boards support different sensor add ons
Sleep and active	10.1 μ A and 7.95 mA	–	15 μ A and 8 mA	11.6 μ A and 46.6 mA
Dimensions	15 \times 11 cm ²	–	25 \times 6 mm ²	58.15 \times 32.5 mm ²
Compatible interfaces	SPI, UART, ADC, Digital, I2C, USB	NA	UART, SPI, I2C, ADC, Digital	SPI, UART, I2C, ADC
Price/cost	\$20	–	\$135	\$215

TABLE II
EXPERIMENTAL SETUP

Parameter	Value
Operational voltage	3.3 V
Clock frequency	8 MHz
3.7 V Li-ion battery	800 mAh
Awake duration	1 sec
Data Size	40 Bytes
Protocols	IEEE 802.15.1 and IEEE 802.15.4
Sensors	Temp., Humidity, Flex, and LDR

TABLE III
CURRENT CONSUMPTION OF MEGAN

Operational State	Current Consumption (mA)		
	Mean	Minimum	Maximum
Sleep	0.0101	0.01	0.0102
Active	7.95	7.81	8.10
Active with Bluetooth	16.44	16.35	16.54
Active with ZigBee	59.65	59.69	59.72

communication modules, which are compatible with SPI, UART, I2C bus. However, the existing works [11], [16], [17] do not allow the user to integrate other wireless modules apart from the integrated module on the PCB of their node. In case of GPIO pins, MEGAN opens all the GPIO pins so that a user can integrate required peripherals, based on applications. On the other hand, MICA2DOT and BT node Rev3 open a limited number of GPIO pins. The node designed by Kumar *et al.* [11] serves only comfort sensing application and does not open GPIO pins for the user. Moreover, MEGAN allows accessing the used GPIO pins by changing jumper setting, where no GPIO pin is dedicated for a specific component. Besides, MEGAN supports all commonly usage peripheral interfacing protocols unlike other [11], [16], [17]. From the table, we infer that MEGAN offers greater flexibility compared to [11], [16], [17], and is more energy-efficient compared to its contemporaries [16], [17]. It is noteworthy that MEGAN is the lowest cost node among MICA2DOT and BT node Rev3. It helps to build a low-cost IoT network where WSN is the backbone. Therefore, MEGAN is useful for multiple IoT applications.

D. Results and Discussion

1) *Current Consumption*: Table III shows the current consumption of MEGAN in the different states, where all components work at 3.3 Volts and the processor runs at 8 MHz internal clock frequency. From the table, it is evident that

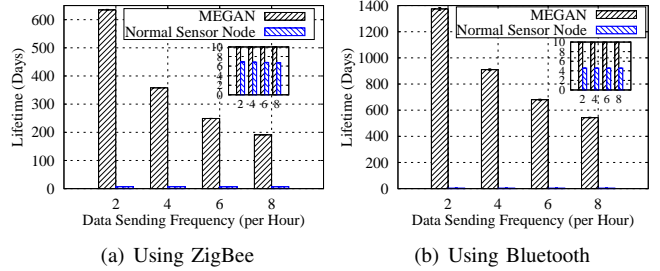

Fig. 8. Lifetime of MEGAN

MEGAN consumes low-current in all states that helps to maximize the lifetime of the node. The basis of significant results is the design of the power management circuit and efficient PCB design. In the sleep cycle, the processor cuts the power supply of communication and sensor/actuator unit, so that the total current consumption of the node depends on the current consumption of the processor in sleep and the rest of circuitry of MEGAN.

2) *Lifetime*: We evaluate the lifetime (\mathcal{L}_{lt}) of MEGAN, which is shown in Fig. 8, while considering traditional sensor node that has no PMC controller, at different sending frequency intervals per hour. Figs. 8(a) and 8(b) show the lifetime of MEGAN using ZigBee and Bluetooth, respectively, including temperature and humidity sensor (Model: DHT22), which consumes 2.5 mA current at 3.3 Volts. The figures show that the lifetime of MEGAN is significantly more compared to the traditional node. In the proposed design, the processor controls the power supply of sensing and communication units in sleep mode as the node does not sense data from the experimental field and does not wirelessly communicate with neighbor nodes in IoT. On the other hand, traditional nodes have no power control circuit to cut the power supply of the sensing and communication unit in sleep mode, but the wireless module of the node goes to the sleep state to reduce the current consumption.

3) *Received Signal Strength Indicator*: Fig. 9 presents the RSSI value of the last received data packet when the distance between the receiving and transmitting antennas and the power of the transmitting antennas are varying [18]. We evaluate the RSSI using ZigBee and Bluetooth in the different places of indoor and outdoor that are shown in Figs. 9(a), 9(b), and 9(c), respectively. In the case of ZigBee, the received sensitivity

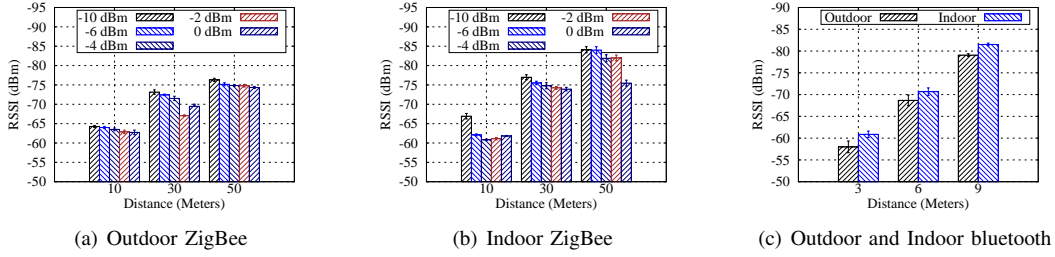

Fig. 9. RSSI analysis of MEGAN

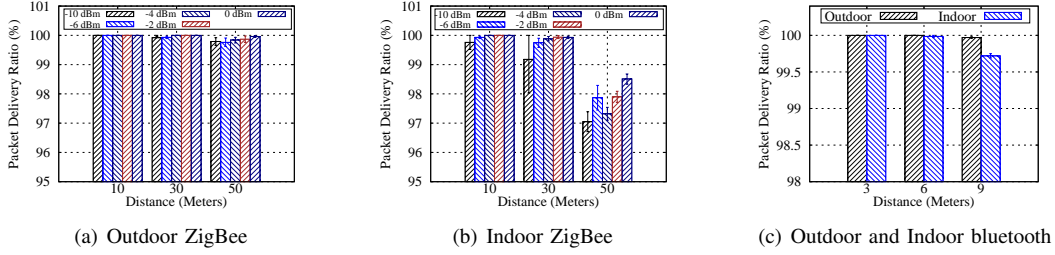

Fig. 10. PDR analysis of MEGAN

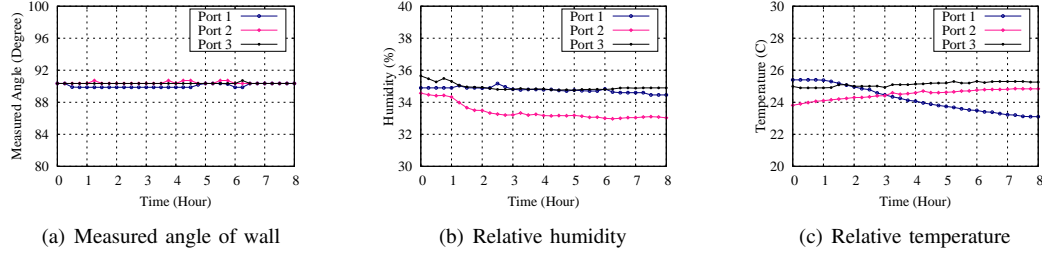

Fig. 11. Testing adaptability of MEGAN

is ≥ -92 dBm. However, in the case of Bluetooth, there is no provision to change the power level of the transmitting antenna, where the received sensitivity is ≥ -84 dBm. These figures signify that the designed node is capable of transmitting healthy packets to the neighbor's nodes. The RSSI value of ZigBee and Bluetooth in outdoor is always higher than that in indoor due to the more obstacle, human movement, and Wi-Fi radio interference compared to outside. The positive effect is due to the optimized hardware design of MEGAN and sufficient power supply in the transmitting time.

4) *Packet Delivery Ratio*: Figs. 10(a) and 10(b) show the PDR in outdoor and indoor environments using ZigBee, respectively, while varying the transmitting power-level with distance. On the other hand, Fig. 10(c) shows PDR in outdoor and indoor environments using Bluetooth, with varying distance. The transmitting interval is 500 ms. The PDR using ZigBee in outdoor is higher compared to indoor because, in outdoor, there are fewer obstacles, Wi-Fi interference, and human movement compared to indoor. On the other hand, in the case of Bluetooth, the PDR in outdoor is slightly more compared to that in indoor. However, the percentage of PDR using Bluetooth is higher than ZigBee, as the Bluetooth protocol creates pair connection before communication between the transmitter and receiver nodes using the master and slave architecture. However, it is noticeable that the overall PDR of

MEGAN using ZigBee and Bluetooth is high due to the high value of RSSI in both cases.

5) *Adaptability*: To evaluate the lifetime, RSSI, and PDR of MEGAN, we used both ZigBee and Bluetooth — which shows the adaptability of MEGAN regarding enabling the interworking of heterogeneous wireless communication protocols. On the other hand, to show that a specific port of our designed sensor node is not dedicated to a particular sensor/actuator, we developed a prototype of the building structure monitoring system with three heterogeneous sensors — flex (F), temperature (T), and humidity (H) attached to each node. The experiment was run in a lab-scale environment for twenty-four hours. The sensors are interfaced with three ports of the node in various combinations with different time intervals, as follows:

$$S1 = \{F, H, T\}, S2 = \{T, F, H\}, \text{ and } S3 = \{H, T, F\}$$

In the first eight hours of the experiment, F, H, and T sensors of set S1 are interfaced with Port 1, Port 2, and Port 3 of the node, respectively. Similarly, for sets S2 and S3, the total collected data of F, H, and T sensors are shown in Figs. 11(a), 11(b), and 11(c), respectively. The changing temperature and humidity of the surrounding environment are depicted in Figs. 11(b), and 11(c). However, the output of the flex sensor is constant for the entire duration. Therefore, it indicates that a

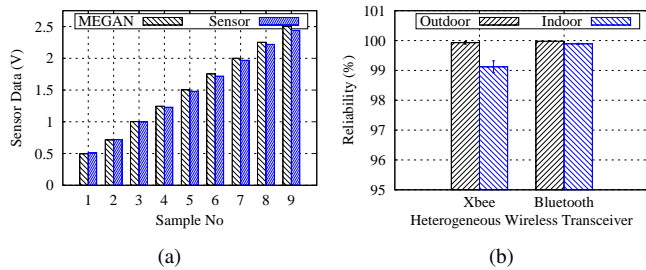

Fig. 12. (a) Data validation and (b) Reliability

port is not fixed for a specific sensor/actuator and the node can concurrently support multiple such devices.

6) *Data Validation*: We performed data validation using a light dependent resistor sensor, as shown in Fig. 12(a), while presenting the raw value in voltage as traditional sensors are more comfortable with the ADC bus. The sensitivity of the ADC channel depends on three factors: (a) power stability, (b) signal noise, and (c) PCB design of a sensor node. From Fig. 12(a), it is shown that the average error lies between ± 0.0245 V, which infers that MEGAN computes precision data of the received sensor data. In MEGAN, we use ground solder masking on the top and bottom side of the node, which, in turn, helps to deduct noise from PCB. Additionally, the power supply section of the node is efficiently designed, which allows controlling the power stability factors.

7) *Reliability*: Fig. 12(b) shows the reliability of MEGAN using ZigBee and Bluetooth. In both the cases, it is evident that MEGAN is highly reliable. Figs. 10 and 12(a) show that the PDR and data accuracy of MEGAN are very high, which positively affects the overall reliability of MEGAN. According to Fig. 12(b), the reliability of MEGAN using Bluetooth is higher than that using ZigBee, as the former creates a secure pairing between the sender and receiver nodes. However, the transmitting range of ZigBee is more than that of Bluetooth.

VI. CONCLUSION

In this paper, we proposed the design of a new sensor node, which is a multi-purpose and adaptable sensor node that can serve many applications of IoT, and yet maintain energy-efficiency standards. Reliability analysis provides a good measure of MEGAN's communication capabilities, with ZigBee and Bluetooth in use. On the provision of a fixed amount of battery capacity – 800 mAh in the experiments – *Lifetime of MEGAN* was found to be 3.77 years using Bluetooth, where sending frequency per hour is two times. Further, MEGAN is the lowest cost (\$20) node among MICA2DOT and BT node Rev3.

In this work, we considered adaptability in the hardware design of the node. Therefore, a user is able to integrate different peripherals according to the requirements. But the user needs to change the corresponding firmware, which may be unfavorable from the user's perspective. In future, the proposed work can be extended to address this issue to enable seamless integration of a peripheral with the capability to manage the corresponding driver of the connected peripheral. Moreover,

future research can explore the integration of wireless charging to the node to ensure continuous operation.

REFERENCES

- [1] J. Santos, J. J. P. C. Rodrigues, J. Casal, K. Saleem, and V. Denisov, "Intelligent personal assistants based on Internet of Things approaches," *IEEE Syst. J.*, vol. 12, no. 2, pp. 1793–1802, June 2018.
- [2] F. K. Shaikh, S. Zeadally, and E. Exposito, "Enabling technologies for green Internet of Things," *IEEE Syst. J.*, vol. 11, no. 2, pp. 983–994, June 2017.
- [3] M. T. Lazarescu, "Design of a wsn platform for long-term environmental monitoring for IoT applications," *IEEE J. Emerg. Sel. Topics Circuits Syst.*, vol. 3, no. 1, pp. 45–54, Mar 2013.
- [4] F. Al-Turjman and S. Alturjman, "Context-sensitive access in Industrial Internet of Things (IIoT) healthcare applications," *IEEE Trans. Ind. Informat.*, vol. 14, no. 6, pp. 2736–2744, June 2018.
- [5] S. Sudevalayam and P. Kulkarni, "Energy harvesting sensor nodes: Survey and implications," *IEEE Commun. Surveys Tuts*, vol. 13, no. 3, pp. 443–461, Third 2011.
- [6] O. B. Akan, O. Cetinkaya, C. Koca, and M. Ozger, "Internet of hybrid energy harvesting things," *IEEE Internet of Things J.*, vol. PP, no. 99, pp. 1–1, 2017.
- [7] S. Sen, B. Swarnakar, and U. Datta, "Design of wireless sensor node to measure vibration and environment parameter for structural health monitoring application," in *proc. Adv. Intell. Syst. Comput.*, vol. 343. New Delhi: Springer India, Feb. 2015, pp. 59–65.
- [8] A. Somov, A. Baranov, D. Spirjakin, and R. Passerone, "Circuit design and power consumption analysis of wireless gas sensor nodes: One-sensor versus two-sensor approach," *IEEE Sensors J.*, vol. 14, no. 6, pp. 2056–2063, June 2014.
- [9] A. Alhalafi, L. Shoui, R. Naous, and B. Shihada, "gTBS: A green task-based sensing for energy efficient wireless sensor networks," in *INFOCOM WKSHPs*, San Francisco, USA, April 2016, pp. 136–143.
- [10] R. Yan, H. Sun, and Y. Qian, "Energy-Aware Sensor Node Design With Its Application in Wireless Sensor Networks," *IEEE Trans. Instrum. Meas.*, vol. 62, no. 5, pp. 1183–1191, May 2013.
- [11] A. Kumar and G. P. Hancke, "An energy-efficient smart comfort sensing system based on the IEEE 1451 standard for green buildings," *IEEE Sensors J.*, vol. 14, no. 12, pp. 4245–4252, Dec 2014.
- [12] L. Catarinucci, S. Guglielmi, R. Colella, and L. Tarricone, "Pattern-reconfigurable antennas and smart wake-up circuits to decrease power consumption in WSN nodes," *IEEE Sensors J.*, vol. 14, no. 12, pp. 4323–4324, Dec 2014.
- [13] D. E. Bellasi, R. Rovatti, L. Benini, and G. Setti, "A low-power architecture for punctured compressed sensing and estimation in wireless sensor-nodes," *IEEE Trans. Circuits Syst.*, vol. 62, no. 5, pp. 1296–1305, May 2015.
- [14] S. Monacos and A. Panangadan, "Wireless sensor node for autonomous monitoring and alerts in remote environments," Patent, May 1, 2014, US Patent App. 14/068,303.
- [15] S. Misra, S. K. Roy, A. Roy, S. Kumar, and S. Goswami, "Universal electronic circuit node for supporting multiple heterogeneous sensors and actuators concurrently," Patent, May 4, 2017, IN Patent Filed No. 201731015829.
- [16] *MICA2DOT Wireless microsensor mote*. [Online]. Available: <https://www.eol.ucar.edu/>
- [17] *BTnode rev3 Product Brief*. [Online]. Available: <http://www.btnode.ethz.ch/>
- [18] T. Rappaport, *Wireless Communications: Principles and Practice*, 2nd ed. Prentice Hall PTR, 2001.