

Digital Image Processing, 3rd ed.

Gonzalez &

Woods

www.ImageProcessingPlace.com

Chapter 2

Digital Image Fundamentals

DIGITAL IMAGE FUNDAMENTALS

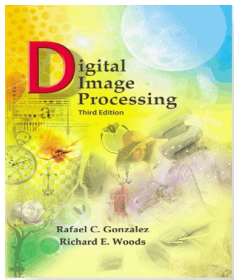

Digital Image Processing, 3rd ed.

Gonzalez &

Woods

www.ImageProcessingPlace.com

Chapter 2

Digital Image Fundamentals

Source: Chapter 02 of DIP, 3E:

Digital Image Fundamentals

- Elements of Visual Perception
 - Structure of Human Eye
 - Image Formation in the Eye
 - Brightness Adaptation and Discrimination
- Light and the Electromagnetic Spectrum
- Image Sensing and Acquisition
 - Image Acquisition Using a Single Sensor
 - Image Acquisition Using Sensor Strips
 - Image Acquisition Using Arrays
 - A Simple Image Formation Model

Not covered topics
shown as this

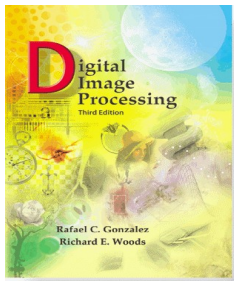

Digital Image Processing, 3rd ed.

Gonzalez &

Woods

www.DigitalImageProcessingPlace.com

Chapter 2

Digital Image Fundamentals

Source: Chapter 02 of DIP, 3E:
Digital Image Fundamentals

- Some Basic Relationships between Pixels

- Neighbors of a Pixel
- Adjacency, Connectivity, Regions, and Boundaries
- Distance Measures

- Image Sampling & Quantization

- Basic concepts
- Representation
- Spatial and Intensity resolution
- Image interpolation

- Mathematical Tools used in DIP

- Array versus Matrix Operations
- Linear versus Non-Linear Operations
- Arithmetic Operations
- Set and Logical Operations
- Vector and Matrix Operations
- Image Transforms
- Probabilistic Methods

Not covered topics
shown as this

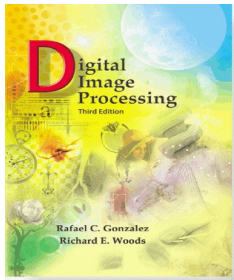

Digital Image Processing, 3rd ed.

Gonzalez &
Woods

www.ImageProcessingPlace.com

Chapter 2 Digital Image Fundamentals

FIGURE 2.1
Simplified
diagram of a cross
section of the
human eye.

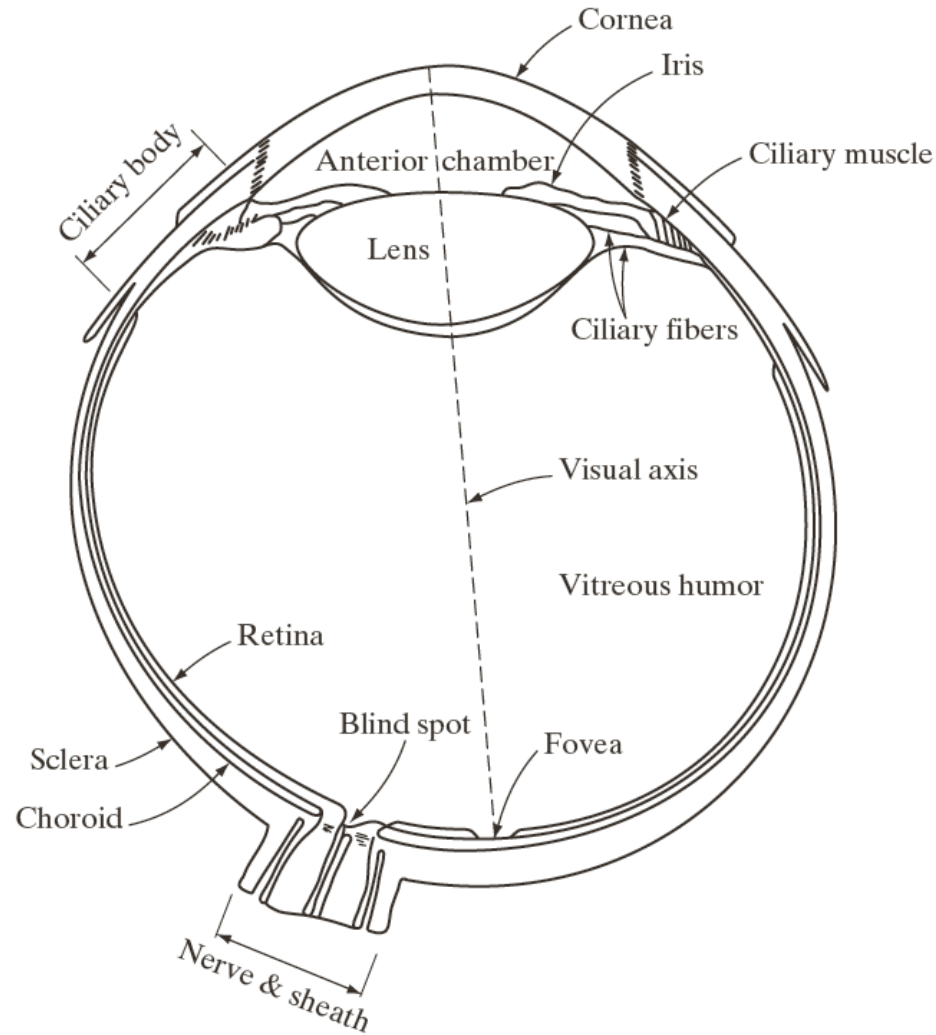

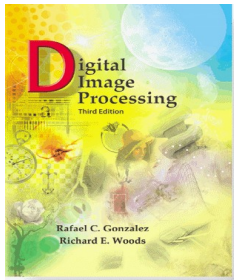

Digital Image Processing, 3rd ed.

Gonzalez &
Woods

www.digitallibraryprocessingplace.com

Chapter 2 Digital Image Fundamentals

- Diameter of Eye: 20mm
- Cornea
 - Tough, Transparent Tissue

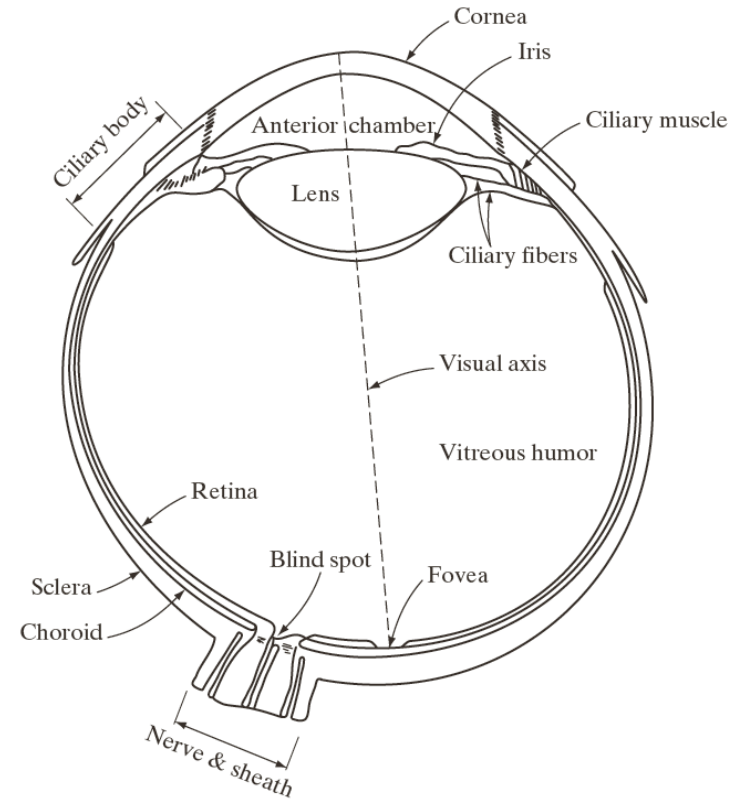

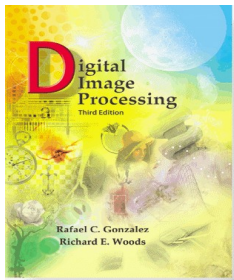

Digital Image Processing, 3rd ed.

Gonzalez &
Woods

www.ImageProcessingPlace.com

Chapter 2 Digital Image Fundamentals

- Iris
 - Controls Aperture (Pupil)
 - Opening: 2mm to 8mm
- Lens
 - Concentric Layers of Fibroid Cells
 - 60% -70% water, 6% fat, protein
 - Absorbs 8% light

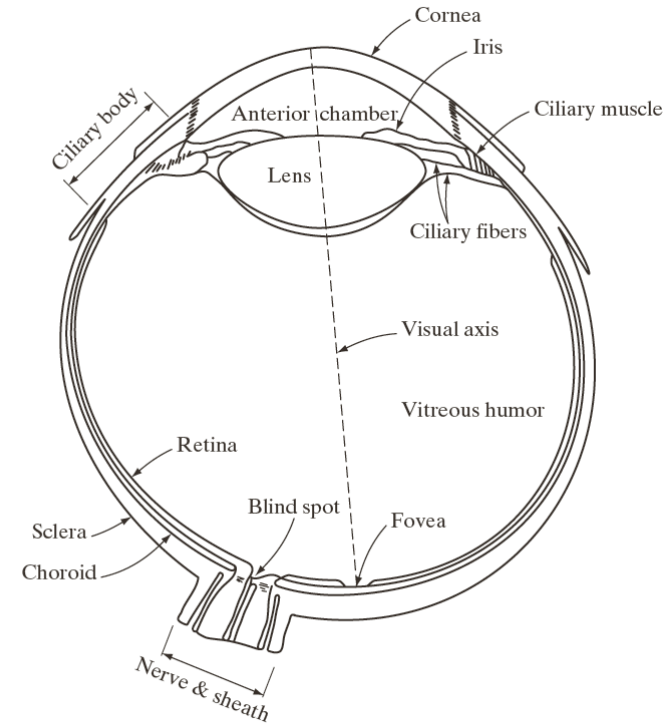

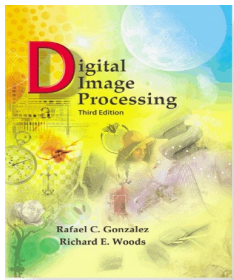

Digital Image Processing, 3rd Edition

Gonzalez &
Woods

www.ImageProcessingPlace.com

Chapter 2 Digital Image Fundamentals

- Retina
 - Innermost membrane
 - Fovea
 - Circular Indentation of 1.5mm diameter
 - Modeled as 1.5mm X 1.5mm (CCD: 5mm X 5mm)
 - Cone & Rod Receptors
 - Blind Spot

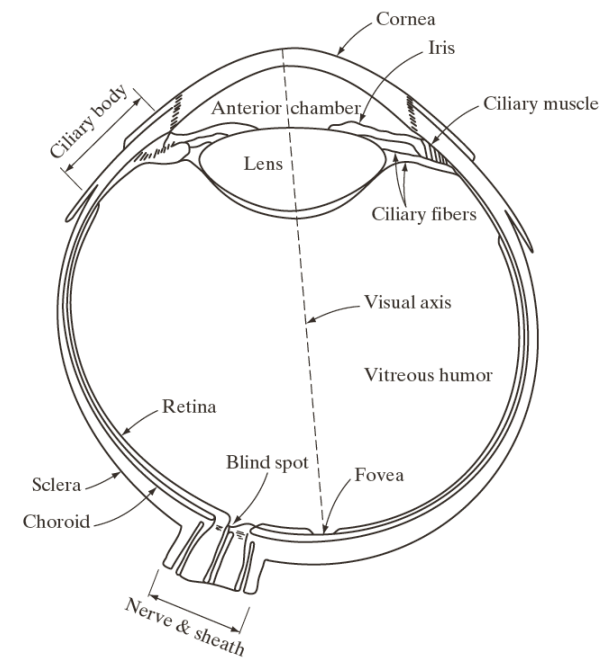

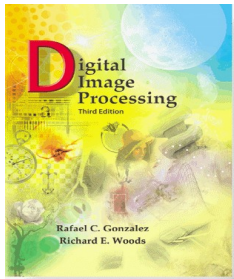

Digital Image Processing, 3rd ed.

Gonzalez &
Woods

www.ImageProcessingPlace.com

Chapter 2 Digital Image Fundamentals

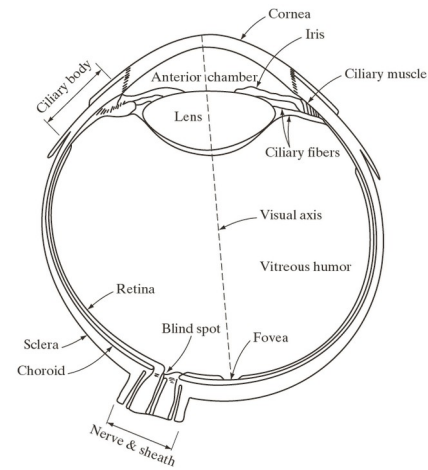

- Cone Receptors (Color)
 - Connected to single nerve, localized around Fovea
 - 1,50,000 elements / mm²
 - 6 to 7 million
 - Photopic or Bright-light Vision
- Rod Receptors (Black-and-White)
 - Multiple rods Connected to single nerve
 - 75 to 150 million
 - Scotopic or Dim-light Vision

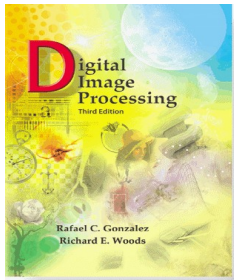

Digital Image Processing, 3rd ed

Gonzalez &
Woods

www.ImageProcessingPlace.com

Chapter 2 Digital Image Fundamentals

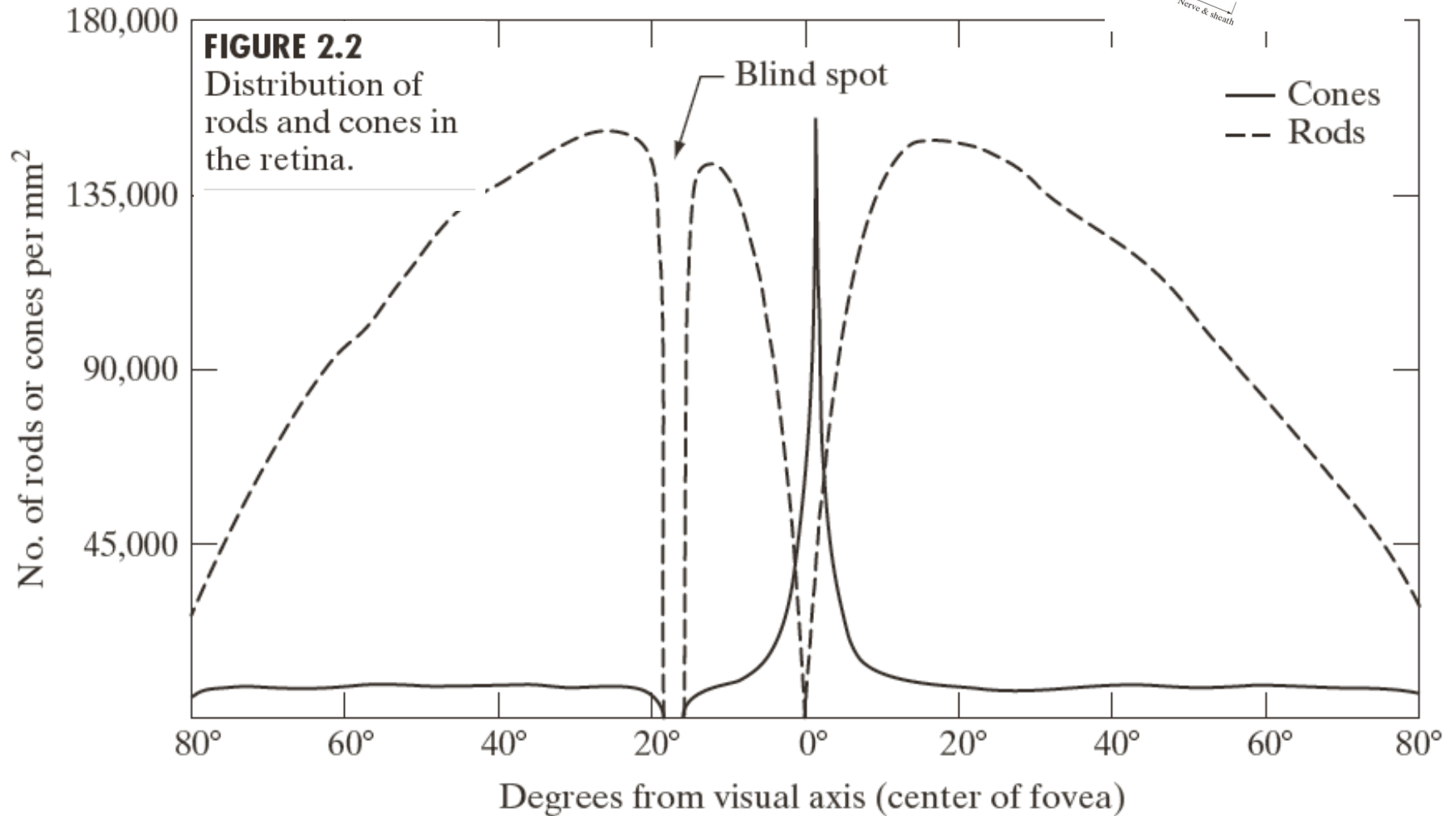
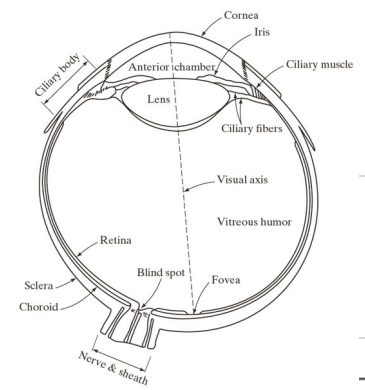

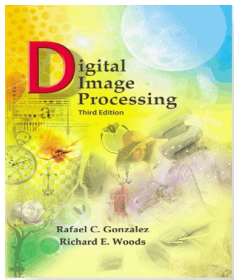

Digital Image Processing, 3rd ed.

Gonzalez &

Woods

www.ImageProcessingPlace.com

Chapter 2

Digital Image Fundamentals

- Image Formation in Camera & Eye
 - What is the fundamental difference?
- Camera
 - Fixed Focal Length of Lens
 - Variable Distance between Lens and Film
- Eye
 - Variable Focal Length of Lens (14mm ~ 17mm)
 - Fixed Distance between Lens and Film (17mm)

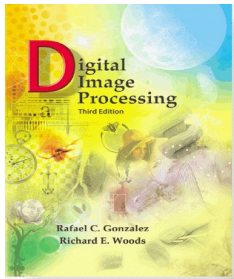

Digital Image Processing, 3rd ed.

Gonzalez &
Woods

www.ImageProcessingPlace.com

Chapter 2 Digital Image Fundamentals

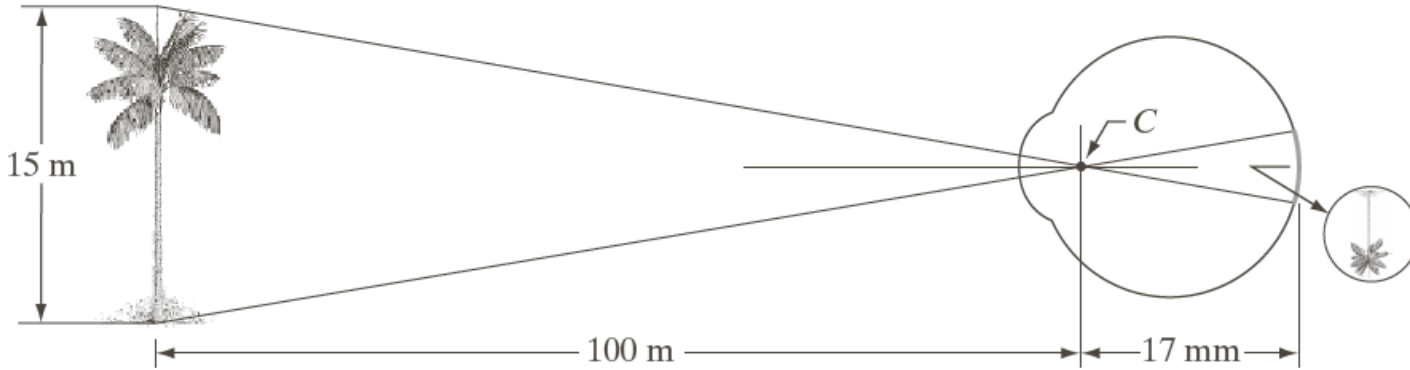
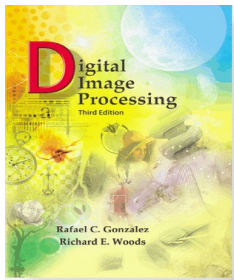

FIGURE 2.3
Graphical representation of the eye looking at a palm tree. Point C is the optical center of the lens.



Digital Image Processing, 3rd ed.

Gonzalez &

Woods

www.ImageProcessingPlace.com

Chapter 2

Digital Image Fundamentals

- Brightness Adaptation & Discrimination
 - How do we perceive the intensity in an image?
- Range of Light Intensity Levels
 - 10^{10} : Scotopic Threshold to Glare Limit
 - 10^6 : Photopic Vision
- Subjective Brightness
 - Brightness perceived by Vision
 - Log function of Light Intensity

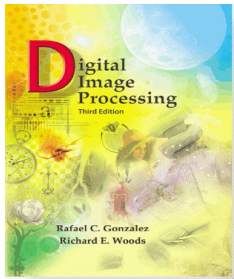

Digital Image Processing, 3rd ed.

Gonzalez &
Woods

www.ImageProcessingPlace.com

Chapter 2 Digital Image Fundamentals

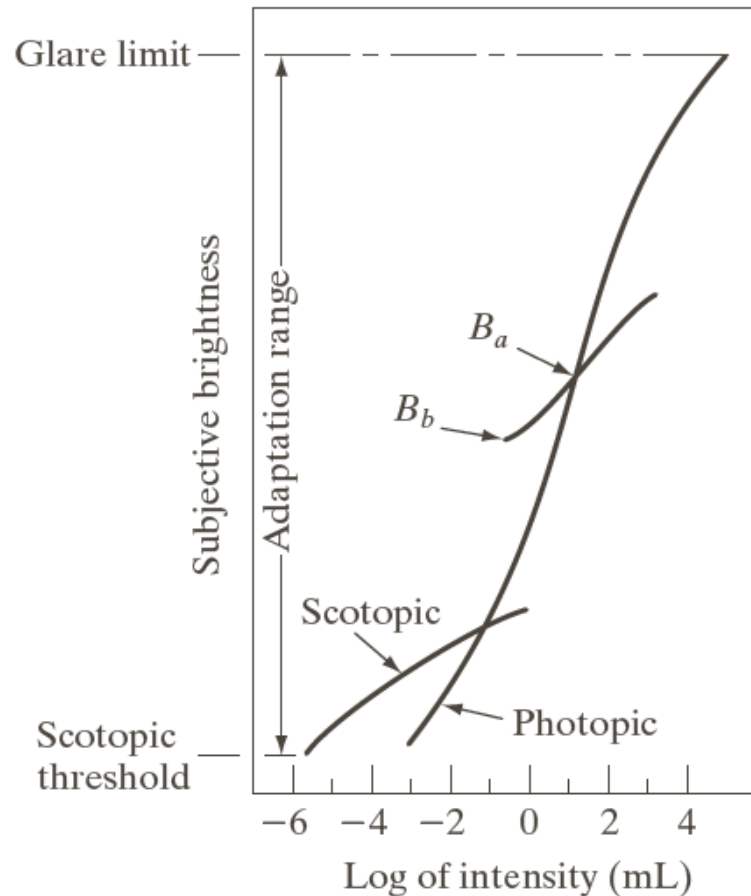
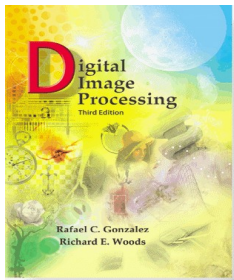

FIGURE 2.4
Range of subjective
brightness
sensations
showing a
particular
adaptation level.



Digital Image Processing, 3rd ed.

Gonzalez &

Woods

www.ImageProcessingPlace.com

Chapter 2

Digital Image Fundamentals

- What is Brightness Adaptation?
 - Wide Range is supported
 - Support is not simultaneous
 - Changes overall sensitivity
- Brightness Adaptation Level
 - Sensitivity at a given condition (B_a)
 - Range gets restricted to a low end (B_b)
 - High end changes the level itself

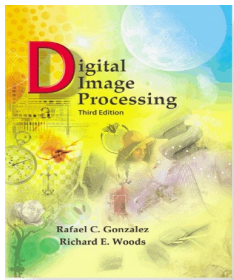

Digital Image Processing, 3rd ed.

Gonzalez &

Woods

www.ImageProcessingPlace.com

Chapter 2

Digital Image Fundamentals

- What is Brightness Discrimination?
 - Ability to discriminate between changes in light intensity at a specific adaptation level
- Experiment for Weber Ratio

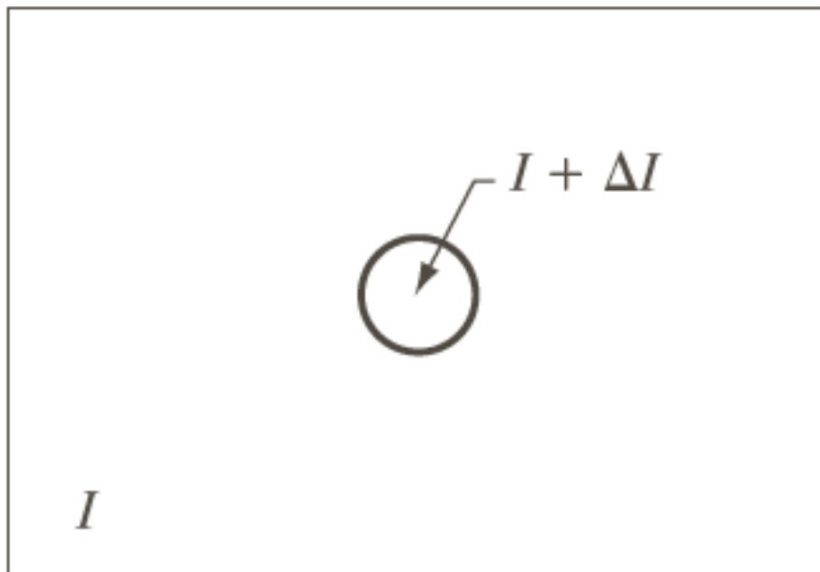
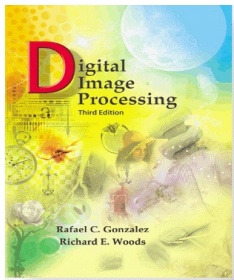

FIGURE 2.5 Basic experimental setup used to characterize brightness discrimination.



Digital Image Processing, 3rd ed.

Gonzalez &

Woods

www.ImageProcessingPlace.com

Chapter 2

Digital Image Fundamentals

- Experiment for Weber Ratio
 - Uniform Back Illumination I
 - Incremental Flash Illumination: ΔI
 - Subject Response: No / Yes
 - ΔI_c discriminable in 50% cases
 - Weber Ratio = $\Delta I_c / I$

Digital Image Processing, 3rd ed.

Gonzalez &
Woods

www.dsp-book.com
www.ImageProcessingPlace.com

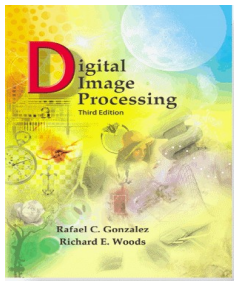

Chapter 2 Digital Image Fundamentals

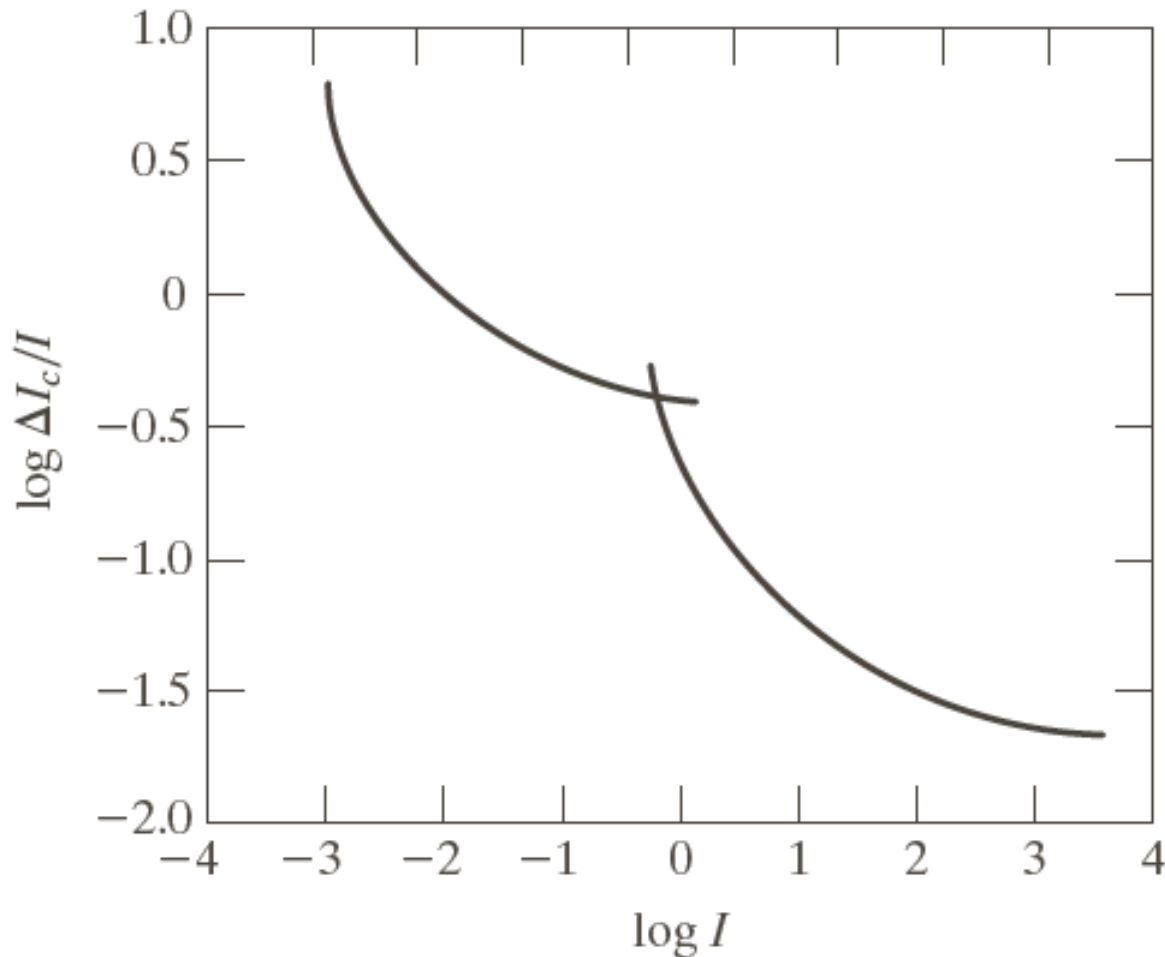
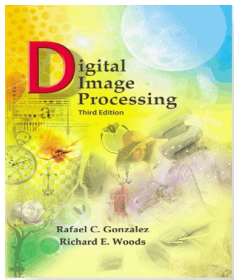

FIGURE 2.6
Typical Weber
ratio as a function
of intensity.



Digital Image Processing, 3rd ed.

Gonzalez &

Woods

www.ImageProcessingPlace.com

Chapter 2

Digital Image Fundamentals

- Weber Ratio
 - Small \rightarrow Good Brightness Discrimination
 - Large \rightarrow Poor Brightness Discrimination
 - Discontinuous functions for rod and cone behavior
- Continuity Behavior
 - Constant I
 - Uniformly varying ΔI
 - One / two dozens of intensities perceived at a time
- Perceived Brightness vs Intensity Phenomena

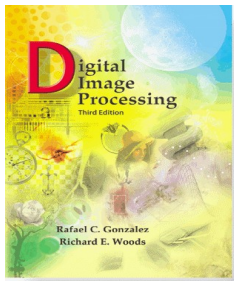

Digital Image Processing, 3rd ed.

Gonzalez &

Woods

www.ImageProcessingPlace.com

Chapter 2

Digital Image Fundamentals

- Mach Bands (after Ernst Mach)
 - Undershoot / Overshoot around boundary of different intensity regions

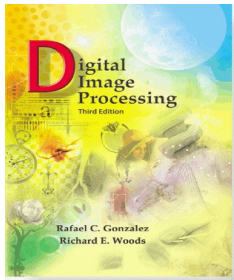

Digital Image Processing, 3rd ed.

Gonzalez &
Woods

www.ImageProcessingPlace.com

Chapter 2 Digital Image Fundamentals

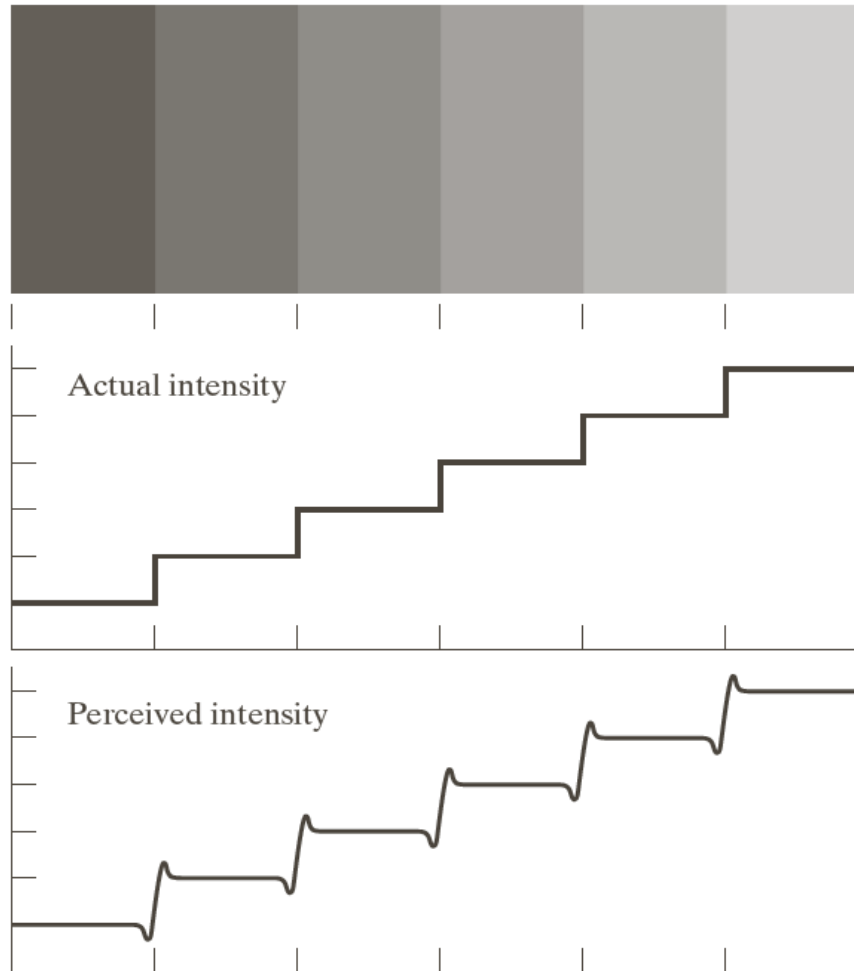

a
b
c

FIGURE 2.7

Illustration of the Mach band effect. Perceived intensity is not a simple function of actual intensity.

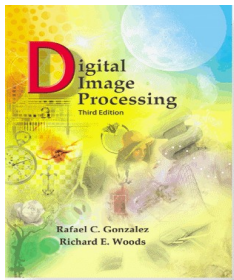

Digital Image Processing, 3rd ed.

Gonzalez &

Woods

www.ImageProcessingPlace.com

Chapter 2

Digital Image Fundamentals

- Simultaneous Contrast
 - Perceived Brightness is not a simple function of intensity

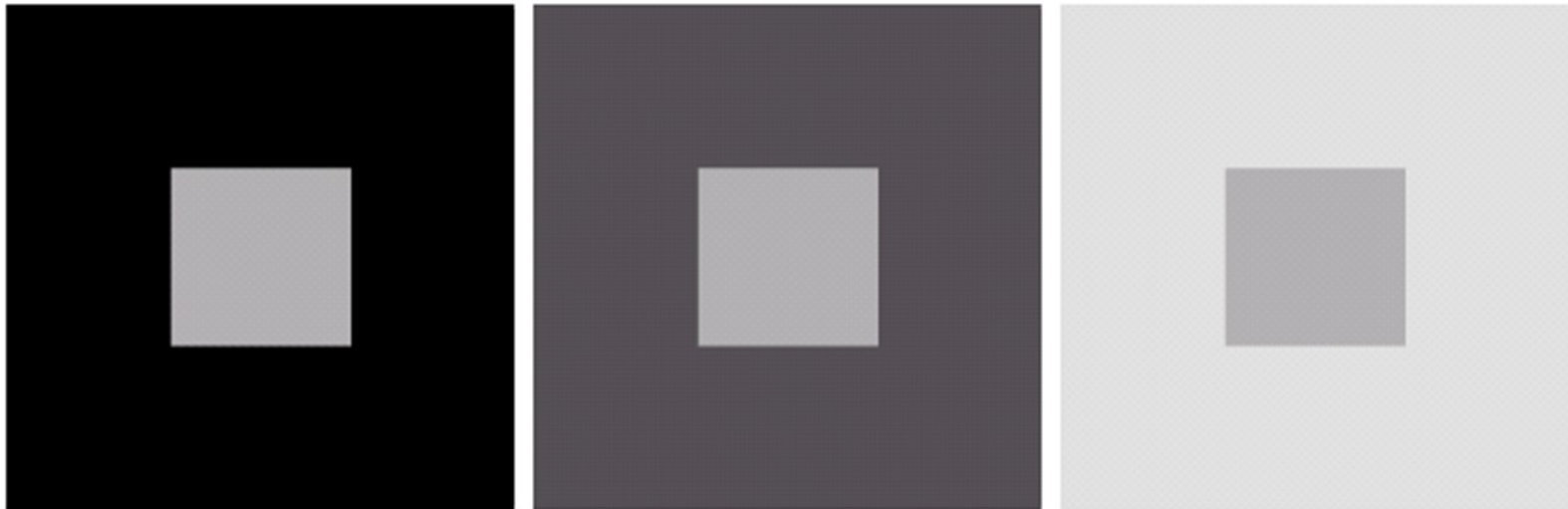

a b c

FIGURE 2.8 Examples of simultaneous contrast. All the inner squares have the same intensity, but they appear progressively darker as the background becomes lighter.

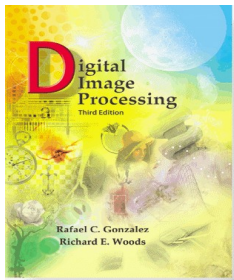

Digital Image Processing, 3rd ed.

Gonzalez &

Woods

www.ImageProcessingPlace.com

Chapter 2

Digital Image Fundamentals

- Optical Illusions
 - Not yet fully understood
 - Eye fills up nonexistent information
 - Wrongly perceives the geometrical properties of objects

Digital Image Processing, 3rd ed.

Gonzalez &
Woods

www.ImageProcessingPlace.com

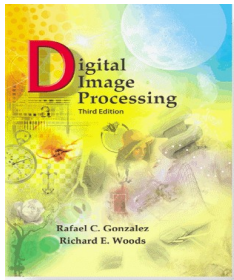

Chapter 2 Digital Image Fundamentals

a b
c d

FIGURE 2.9 Some well-known optical illusions.

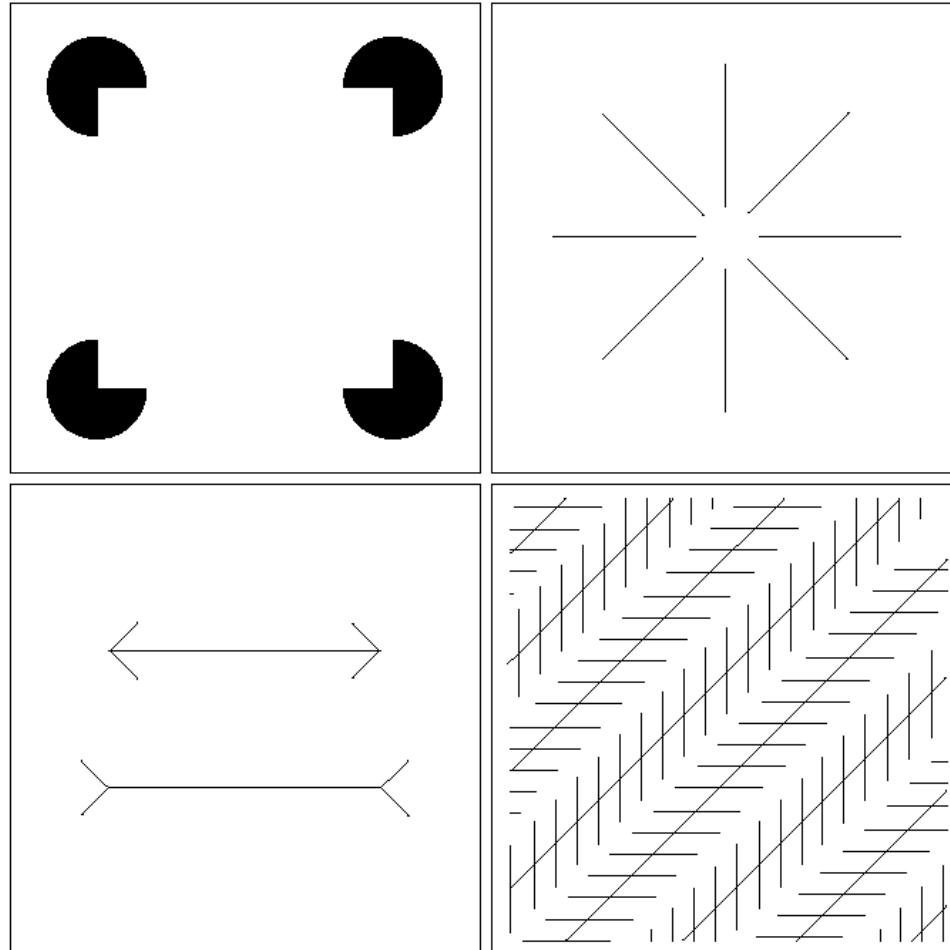

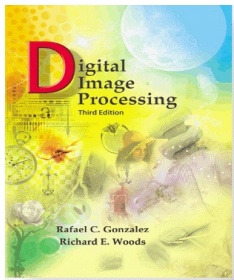

Digital Image Processing, 3rd ed.

Gonzalez &

Woods

www.ImageProcessingPlace.com

Chapter 2

Digital Image Fundamentals

- Light and EM Spectrum
 - $\lambda = c/\nu$
 - λ = Wavelength of light (m)
 - c = Speed of light
 - ν = Frequency of light (Hz)
 - $E = h\nu$
 - E = Energy
 - h = Planck's Constant

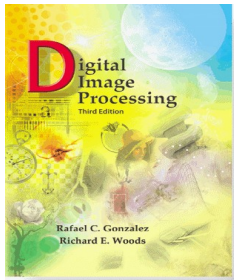

Digital Image Processing, 3rd ed.

Gonzalez &
Woods

www.ImageProcessingPlace.com

Chapter 2 Digital Image Fundamentals

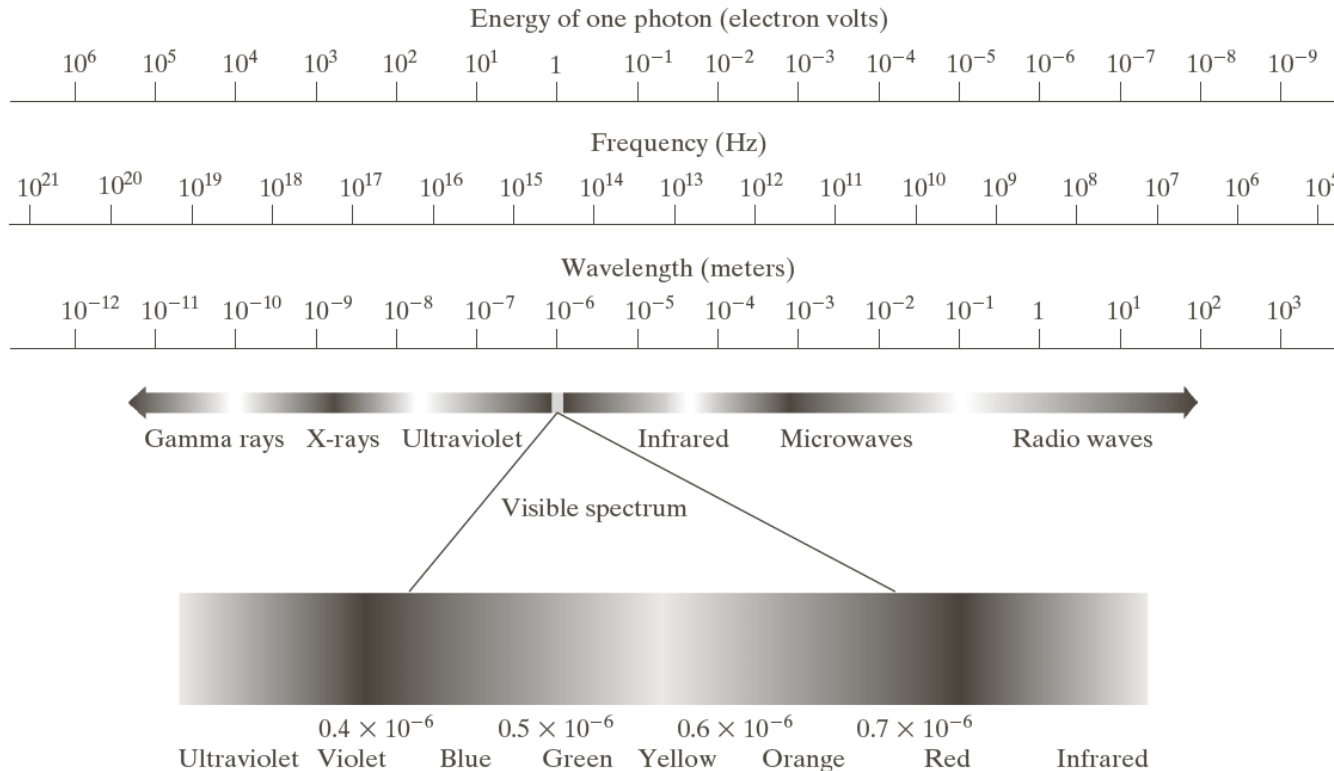
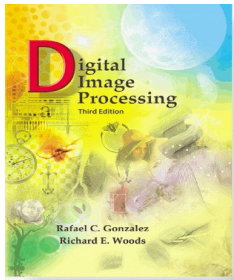

FIGURE 2.10 The electromagnetic spectrum. The visible spectrum is shown zoomed to facilitate explanation, but note that the visible spectrum is a rather narrow portion of the EM spectrum.



Digital Image Processing, 3rd ed.

Gonzalez &

Woods

www.ImageProcessingPlace.com

Chapter 2

Digital Image Fundamentals

- Visible Band: Violet (430nm) ~ Red (790nm)

FIGURE 2.11

Graphical
representation of
one wavelength.

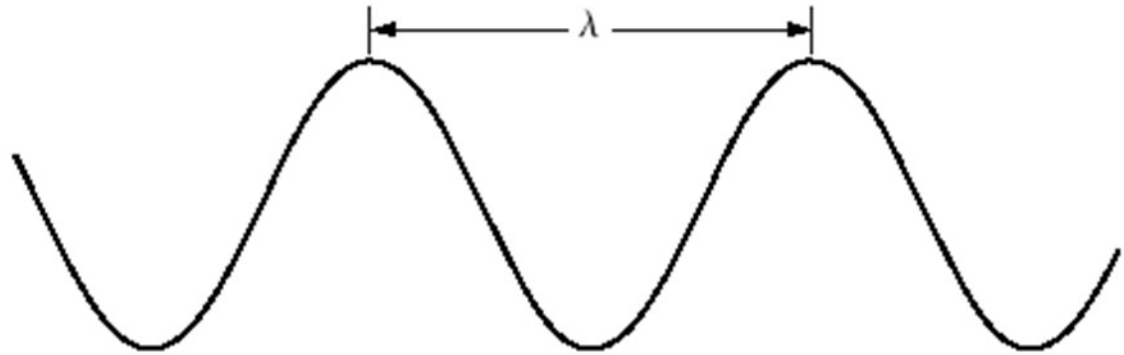

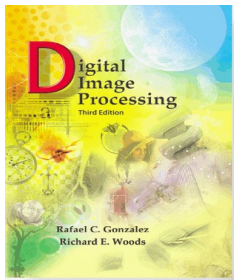

Digital Image Processing, 3rd ed.

Gonzalez &

Woods

www.ImageProcessingPlace.com

Chapter 2

Digital Image Fundamentals

- Monochromatic / Achromatic Light Source
 - Intensity
- Chromatic Light Source
 - Radiance
 - Energy flowing from a light source (Watts)
 - Luminance
 - Energy Perceived by an observer (Lumens)
 - Brightness
 - Subjective descriptor of light perception

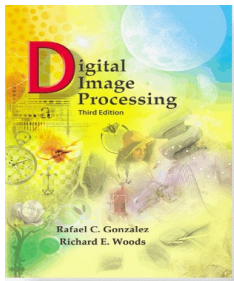

Digital Image Processing, 3rd ed.

Gonzalez &

Woods

www.ImageProcessingPlace.com

Chapter 2

Digital Image Fundamentals

- Image Acquisition
 - Single Sensor
 - Sensor Strip
 - Sensor Array

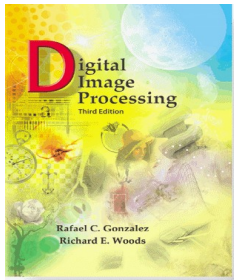

Digital Image Processing, 3rd ed.

Gonzalez &
Woods

www.ImageProcessingPlace.com

Chapter 2 Digital Image Fundamentals

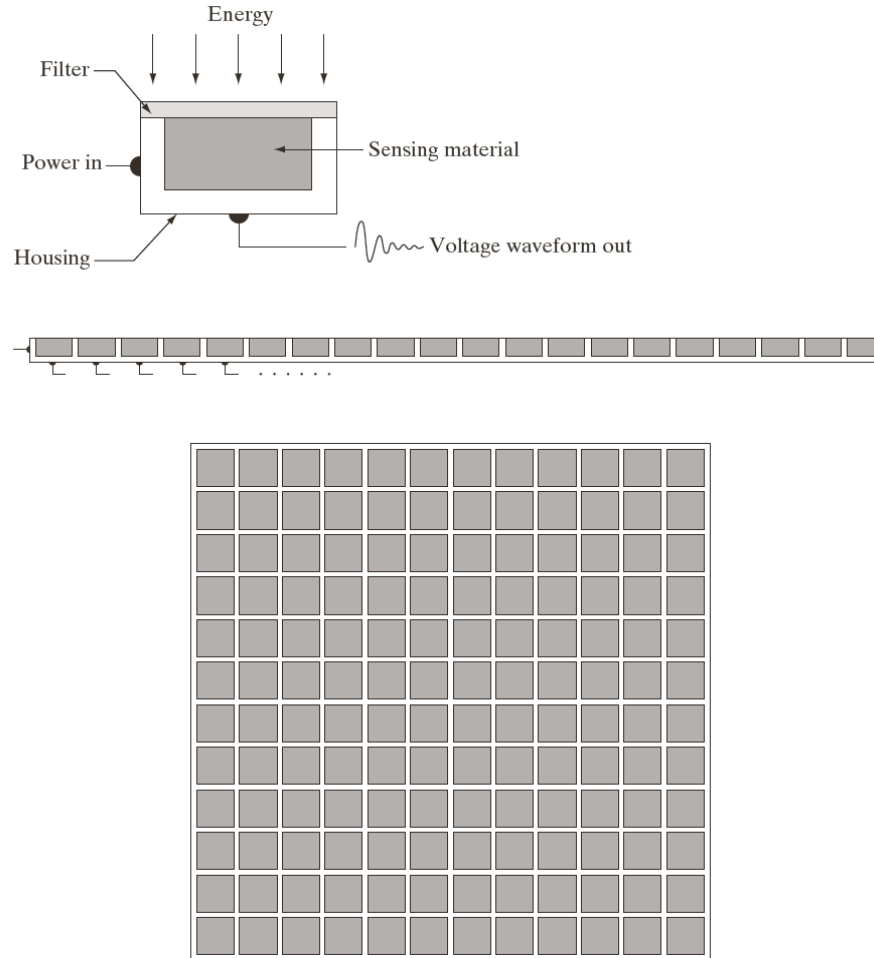

a
b
c

FIGURE 2.12
(a) Single imaging sensor.
(b) Line sensor.
(c) Array sensor.

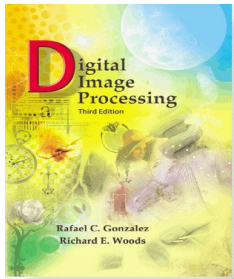

Digital Image Processing, 3rd ed.

Gonzalez &
Woods

www.ImageProcessingPlace.com

Chapter 2 Digital Image Fundamentals

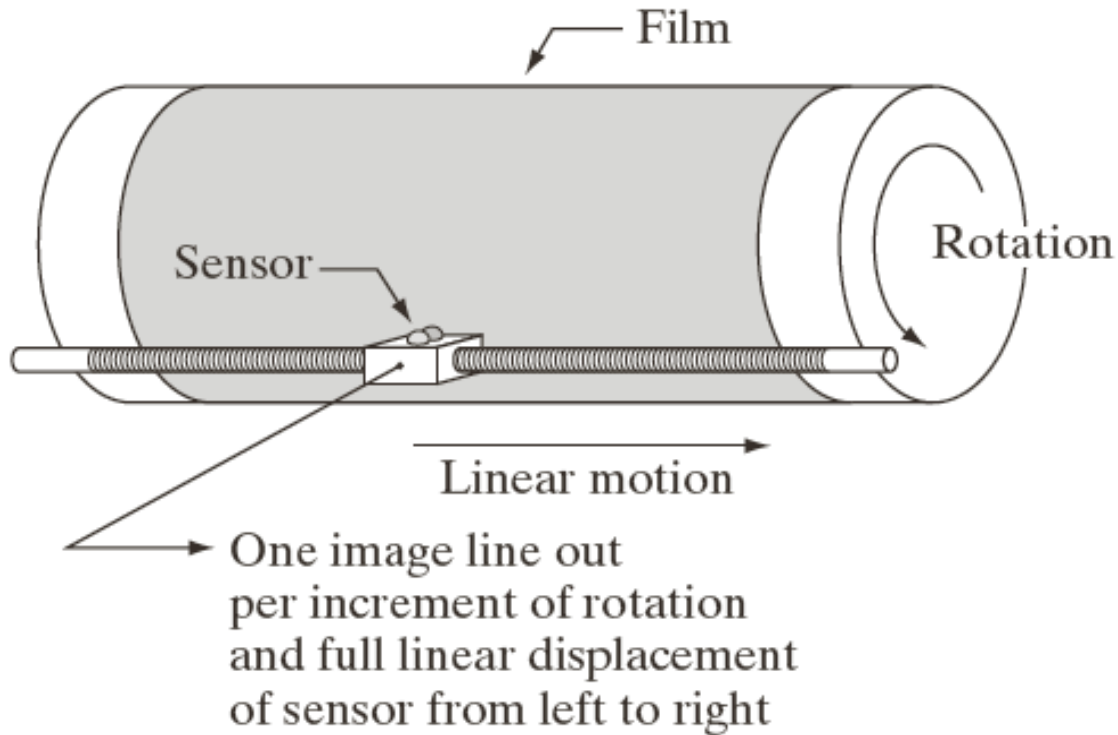
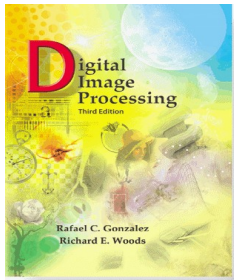

FIGURE 2.13

Combining a single sensor with motion to generate a 2-D image.



Digital Image Processing, 3rd ed.

Gonzalez &
Woods

www.ImageProcessingPlace.com

Chapter 2 Digital Image Fundamentals

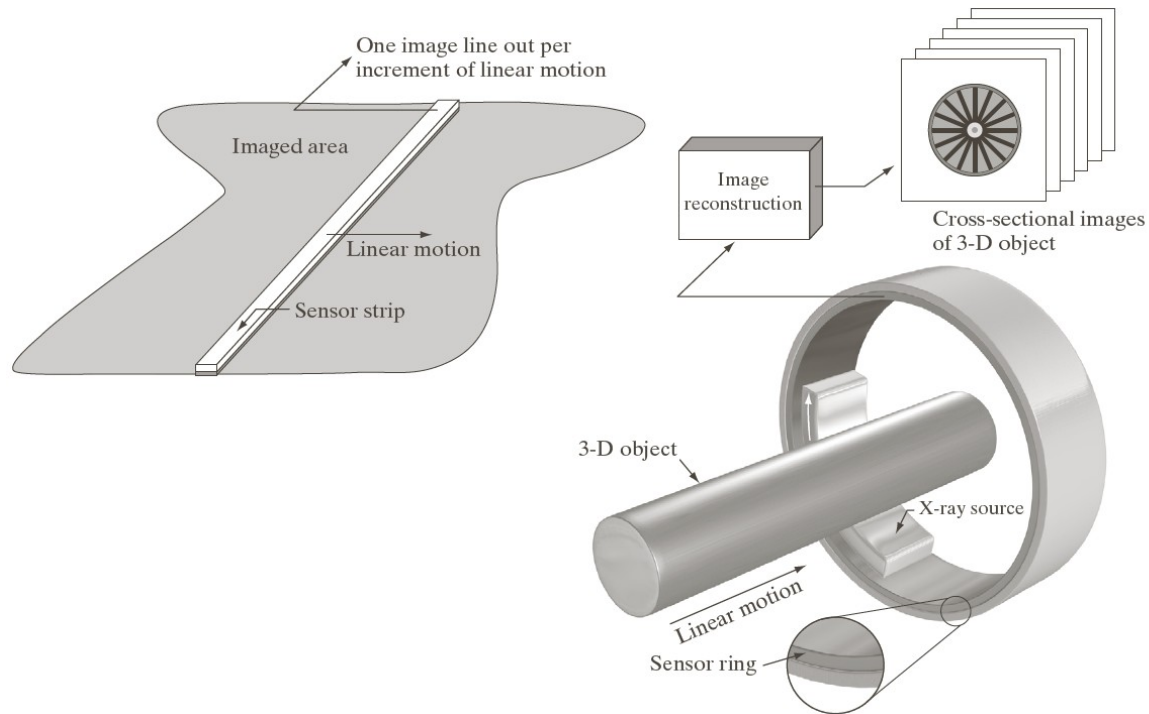

a b

FIGURE 2.14 (a) Image acquisition using a linear sensor strip. (b) Image acquisition using a circular sensor strip.

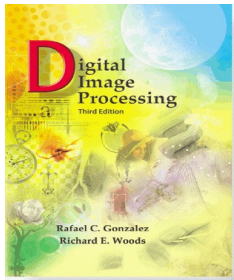

Digital Image Processing, 3rd ed.

Gonzalez &
Woods

www.ImageProcessingPlace.com

Chapter 2 Digital Image Fundamentals

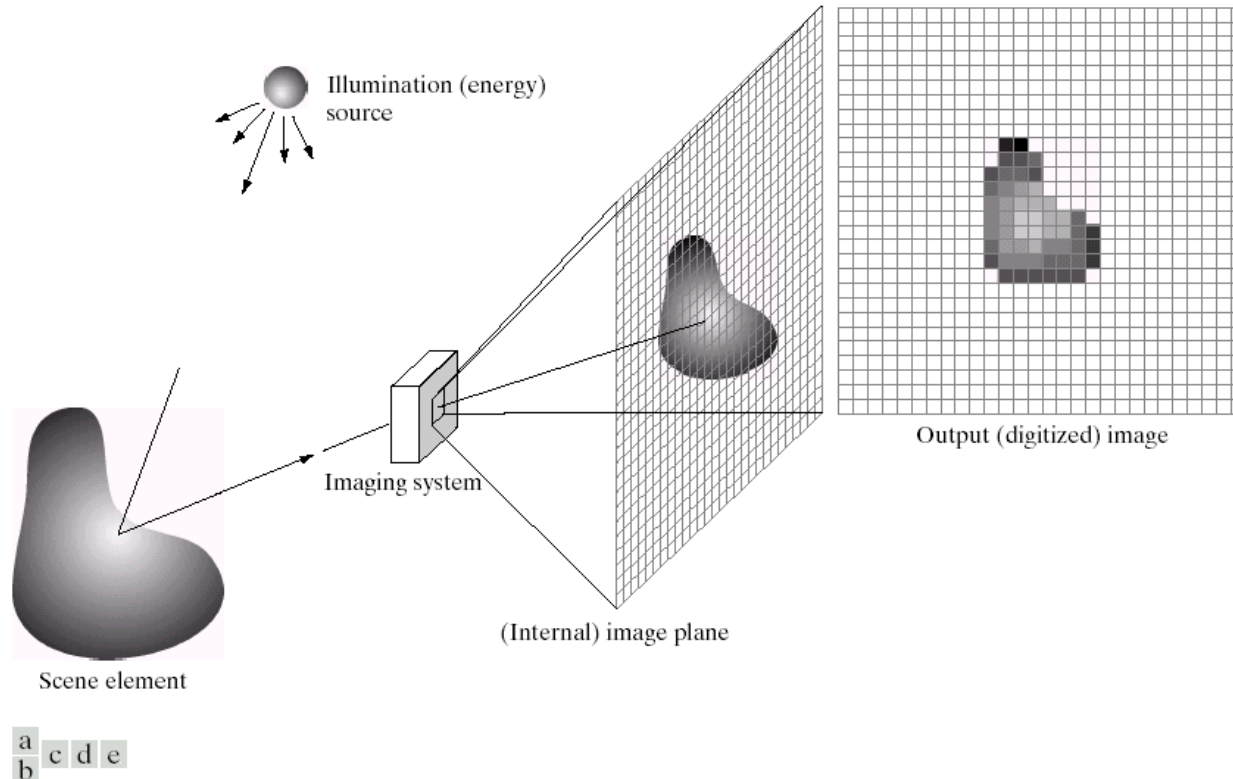
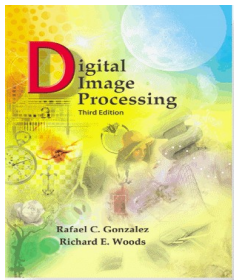

FIGURE 2.15 An example of the digital image acquisition process. (a) Energy (“illumination”) source. (b) An element of a scene. (c) Imaging system. (d) Projection of the scene onto the image plane. (e) Digitized image.



Digital Image Processing, 3rd ed.

Gonzalez &

Woods

www.ImageProcessingPlace.com

Chapter 2

Digital Image Fundamentals

- Sensor Array Technology
- CCD: Charge-Coupled Device
 - Analog
 - Charge moves between capacitative bins
- CMOS APS: CMOS Active Pixel Sensor
 - Photo-detector + Amplifier @ Pixel
 - Used in Cell-Phone Camera / Webcam

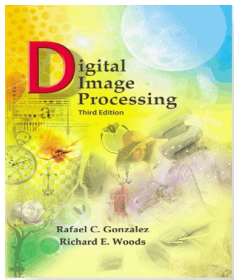

Digital Image Processing, 3rd ed.

Gonzalez &

Woods

www.ImageProcessingPlace.com

Chapter 2

Digital Image Fundamentals

- Image Formation
 - $f(x,y)$ is an image function where
 - $0 < f(x,y) < \infty$
 - $f(x,y) = i(x,y) * r(x,y)$ where
 - $0 < i(x,y) < \infty$: Illumination
 - $0 < r(x,y) < 1$: Reflectance / Transmittance

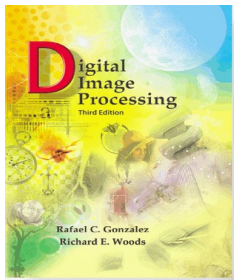

Digital Image Processing, 3rd ed.

Gonzalez &

Woods

www.ImageProcessingPlace.com

Chapter 2

Digital Image Fundamentals

- Typical Illumination
 - Sun, Clear Sky: 90,000 lm/m².
 - Sun, Cloudy Sky: 10,000 lm/m².
 - Full Moon, Clear Sky: 0.1 lm/m².
 - Commercial Office: 1,000 lm/m².

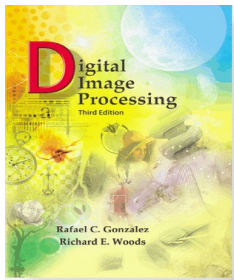

Digital Image Processing, 3rd ed.

Gonzalez &

Woods

www.ImageProcessingPlace.com

Chapter 2

Digital Image Fundamentals

- Typical Reflectance
 - Black Velvet: 0.01
 - Stainless Steel: 0.65
 - Flat White Wall Paint: 0.80
 - Silver-Plated Metal: 0.90
 - Snow: 0.93

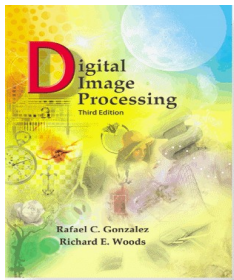

Digital Image Processing, 3rd ed.

Gonzalez &

Woods

www.ImageProcessingPlace.com

Chapter 2

Digital Image Fundamentals

- Intensity of a Monochrome Image at (u,v)
 - $L_{\min} \leq f(u,v) \leq L_{\max}$
 - $L_{\min} > 0$ and L_{\max} is Finite
 - $L_{\min} = i_{\min} * r_{\min}$ and $L_{\max} = i_{\max} * r_{\max}$
 - Typical: $L_{\min} \sim 10$ and $L_{\max} \sim 1000$
 - $[L_{\min}, L_{\max}]$: Grey / Intensity Scale
 - Translate to $[0, L-1]$

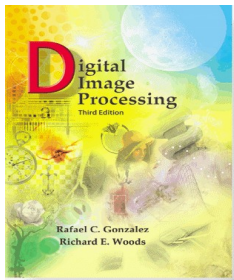

Digital Image Processing, 3rd ed.

Gonzalez &

Woods

www.ImageProcessingPlace.com

Chapter 2

Digital Image Fundamentals

- Sampling for Image Formation
 - Single Sensor
 - Guided by mechanical motion – can be very accurate
 - Limited by optical system
 - Sensor Strip
 - No. of Sensor decide sampling in one dimension
 - Mechanical motions decides the other
 - Sensor Array
 - No. of Sensor decide sampling in both dimensions

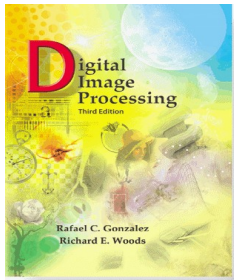

Digital Image Processing, 3rd ed.

Gonzalez &
Woods

www.ImageProcessingPlace.com

Chapter 2 Digital Image Fundamentals

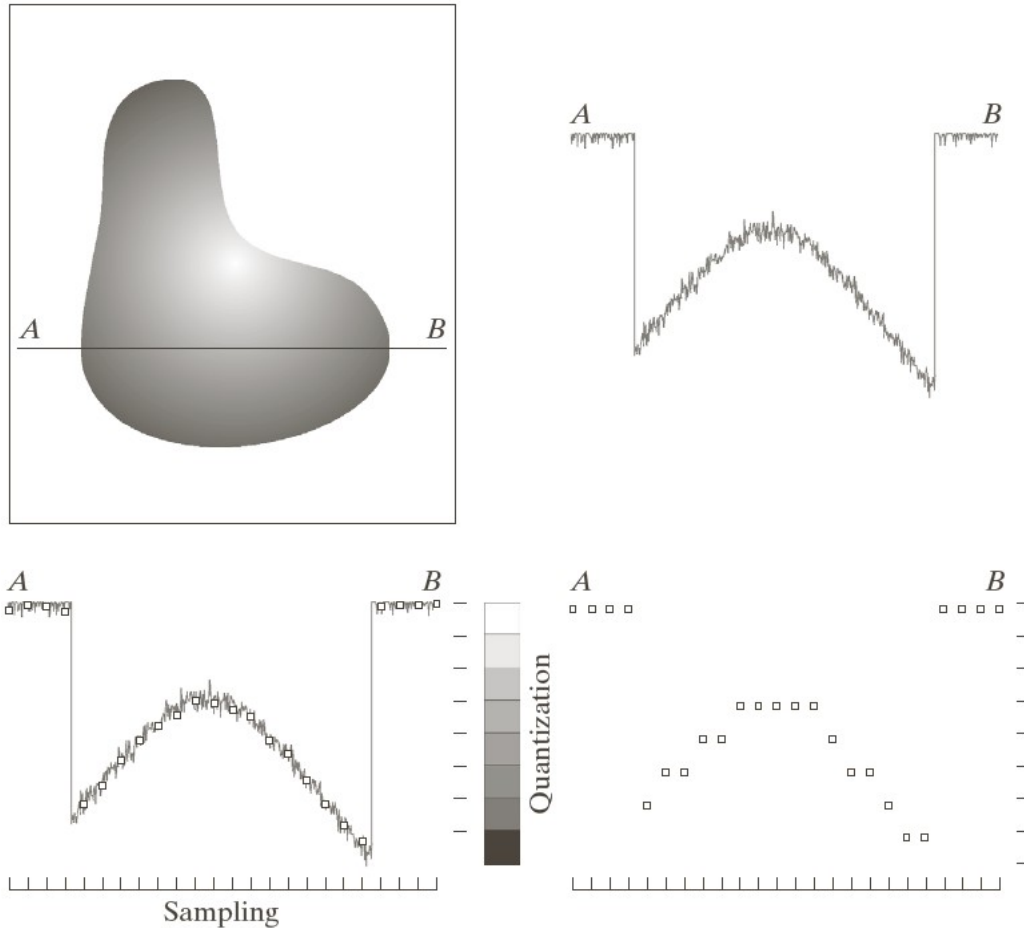

a b
c d

FIGURE 2.16
Generating a digital image. (a) Continuous image. (b) A scan line from *A* to *B* in the continuous image, used to illustrate the concepts of sampling and quantization. (c) Sampling and quantization. (d) Digital scan line.

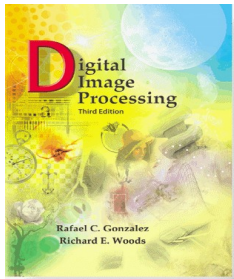

Digital Image Processing, 3rd ed.

Gonzalez &
Woods

www.ImageProcessingPlace.com

Chapter 2 Digital Image Fundamentals

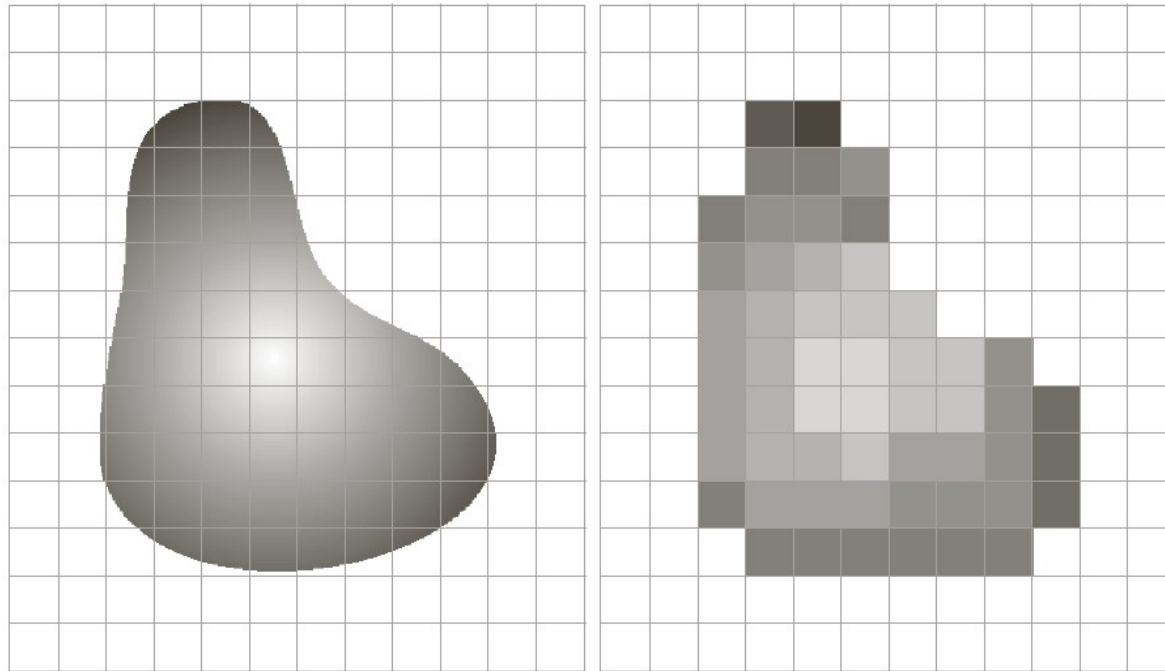

a b

FIGURE 2.17 (a) Continuous image projected onto a sensor array. (b) Result of image sampling and quantization.

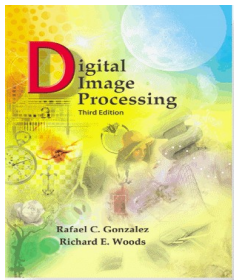

Digital Image Processing, 3rd ed.

Gonzalez &

Woods

www.ImageProcessingPlace.com

Chapter 2

Digital Image Fundamentals

- Image Representation
 - 3-D Function Plot (surface with intensity fluctuations)
 - Too detailed
 - Difficult for inference
 - 2-D Visual Intensity Array
 - Good for visualization
 - Less amenable to computation
 - 2-D Numerical Array
 - Easy for computation
 - Large in data volume

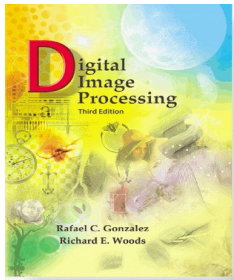

Digital Image Processing, 3rd ed.

Gonzalez &
Woods

www.ImageProcessingPlace.com

Chapter 2 Digital Image Fundamentals

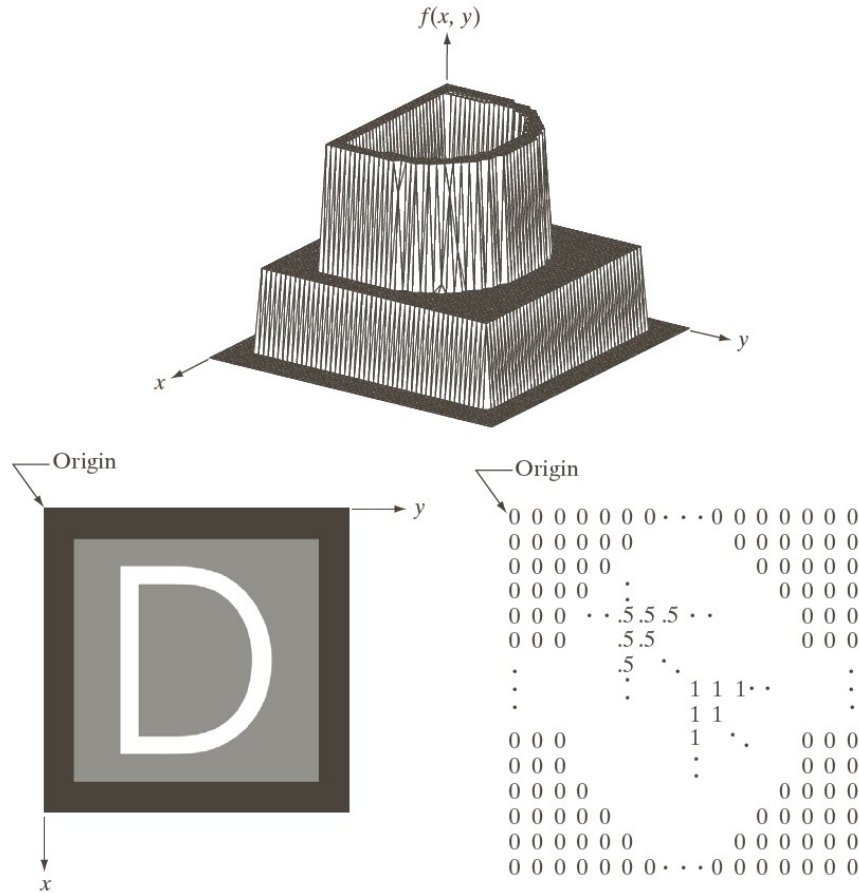

a
b c

FIGURE 2.18

(a) Image plotted as a surface.

(b) Image displayed as a visual intensity array.

(c) Image shown as a 2-D numerical array (0, .5, and 1 represent black, gray, and white, respectively).

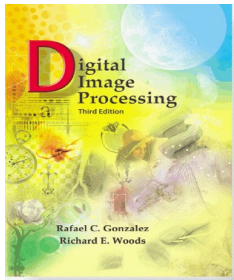

Digital Image Processing, 3rd ed.

Gonzalez &

Woods

www.ImageProcessingPlace.com

Chapter 2

Digital Image Fundamentals

- Image Representation

$$A = \begin{bmatrix} 1 & 2 & 3 & 4 \\ 5 & 6 & 7 & 8 \\ 9 & 10 & 11 & 12 \\ 13 & 14 & 15 & 16 \end{bmatrix} = \begin{bmatrix} a_{00} & a_{01} & a_{02} & a_{03} \\ a_{10} & a_{11} & a_{12} & a_{13} \\ a_{20} & a_{21} & a_{22} & a_{23} \\ a_{30} & a_{31} & a_{32} & a_{33} \end{bmatrix} = \begin{bmatrix} R_0 \\ R_1 \\ R_2 \\ R_3 \end{bmatrix}$$

$$= [\{1, 2, 3, 4\}, \{5, 6, 7, 8\}, \{9, 10, 11, 12\}, \{13, 14, 15, 16\}]$$

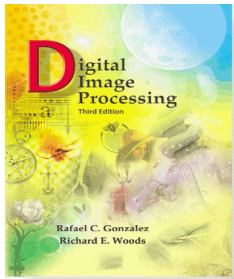

Digital Image Processing, 3rd ed.

Gonzalez &
Woods

www.ImageProcessingPlace.com

Chapter 2 Digital Image Fundamentals

$$f(x, y) = \begin{bmatrix} f(0,0) & f(0,1) & \cdots & f(0,N-1) \\ f(1,0) & f(1,1) & \cdots & f(1,N-1) \\ \vdots & \vdots & & \vdots \\ f(M-1,0) & f(M-1,1) & \cdots & f(M-1,N-1) \end{bmatrix}$$

$$\mathbf{A} = \begin{bmatrix} a_{0,0} & a_{0,1} & \cdots & a_{0,N-1} \\ a_{1,0} & a_{1,1} & \cdots & a_{1,N-1} \\ \vdots & \vdots & & \vdots \\ a_{M-1,0} & a_{M-1,1} & \cdots & a_{M-1,N-1} \end{bmatrix}$$

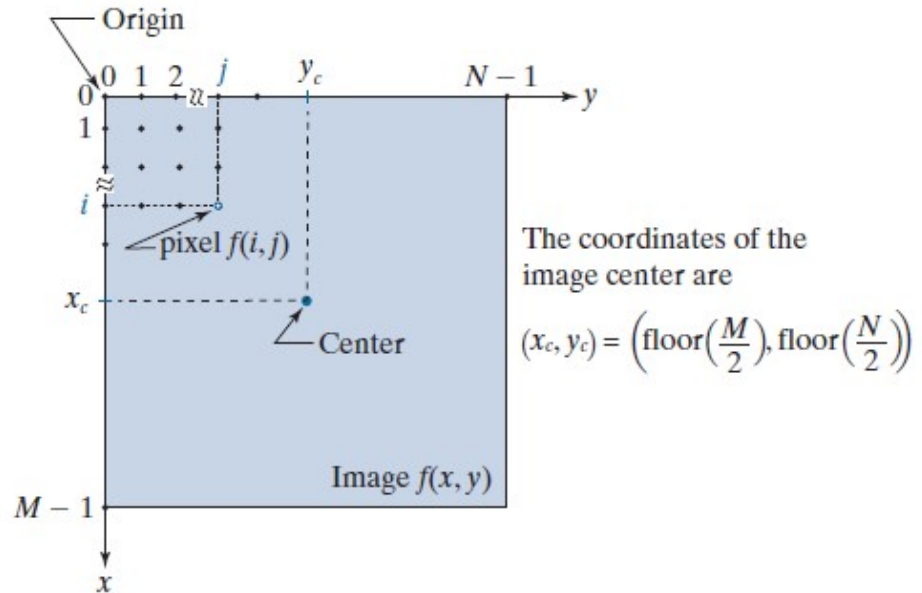

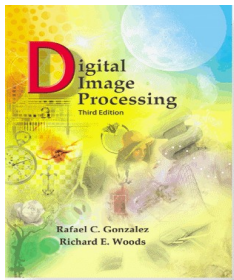

Digital Image Processing, 3rd ed.

Gonzalez &

Woods

www.ImageProcessingPlace.com

Chapter 2

Digital Image Fundamentals

- Image Quantization
 - Mapping Intensity values to a (small) range of integers $[0, L - 1]$, $L = 2^k$.
 - Image Size = N^2k .

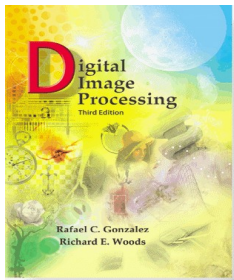

Digital Image Processing, 3rd ed.

Gonzalez &

Woods

www.ImageProcessingPlace.com

Chapter 2

Digital Image Fundamentals

- Image Quantization
 - Dynamic Range of Grey Values
 - Ratio of *Maximum measurable intensity* to *Minimum detectable intensity*
 - Upper Limit: Decided by Saturation
 - Lower Limit: Decided by Noise
 - Contrast
 - Maximum Intensity – Minimum Intensity

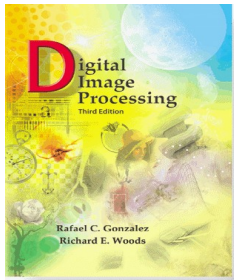

Digital Image Processing, 3rd ed.

Gonzalez &

Woods

www.ImageProcessingPlace.com

Chapter 2

Digital Image Fundamentals

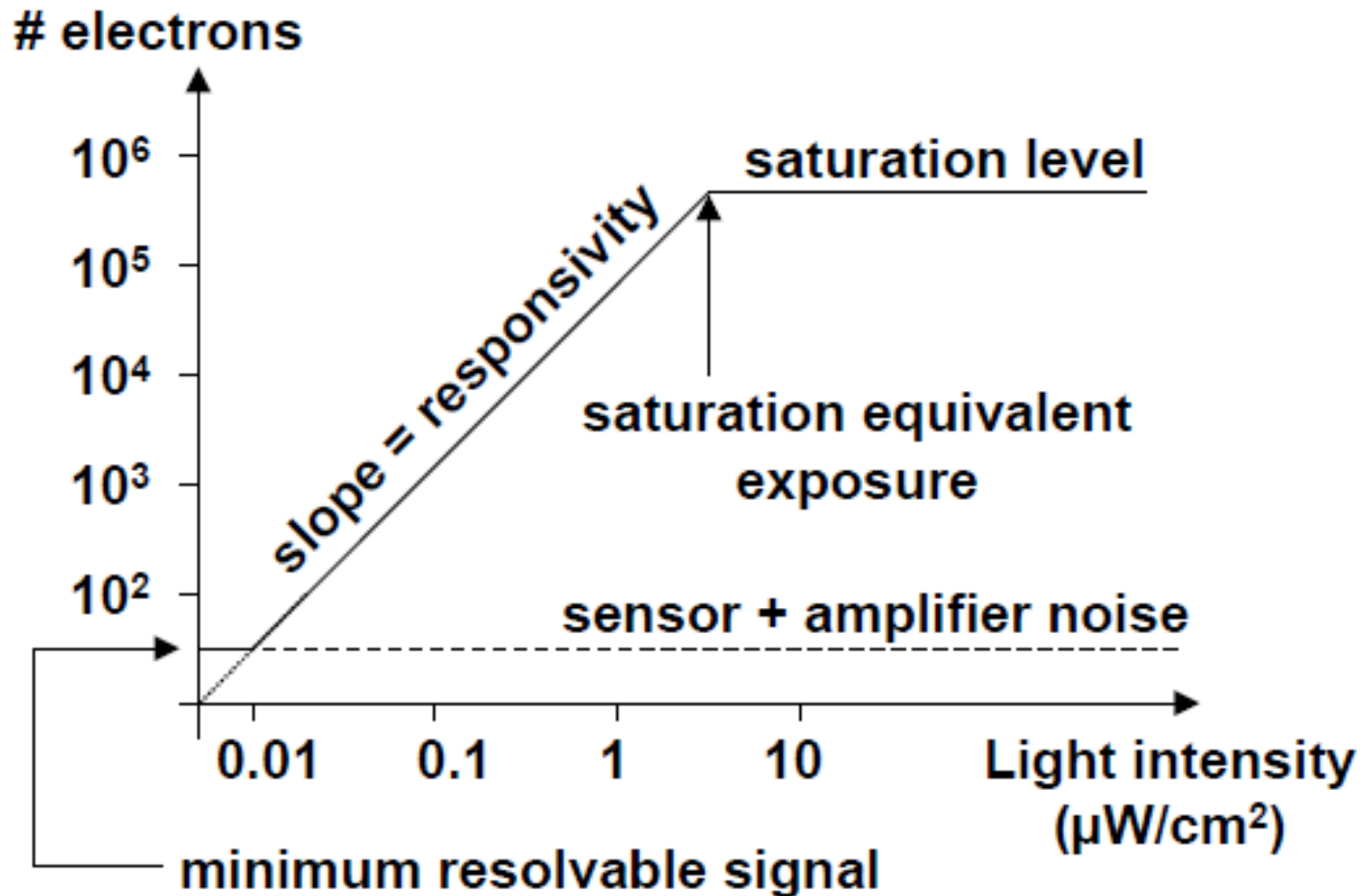

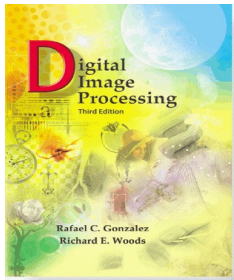

Digital Image Processing, 3rd ed.

Gonzalez &
Woods

www.ImageProcessingPlace.com

Chapter 2 Digital Image Fundamentals

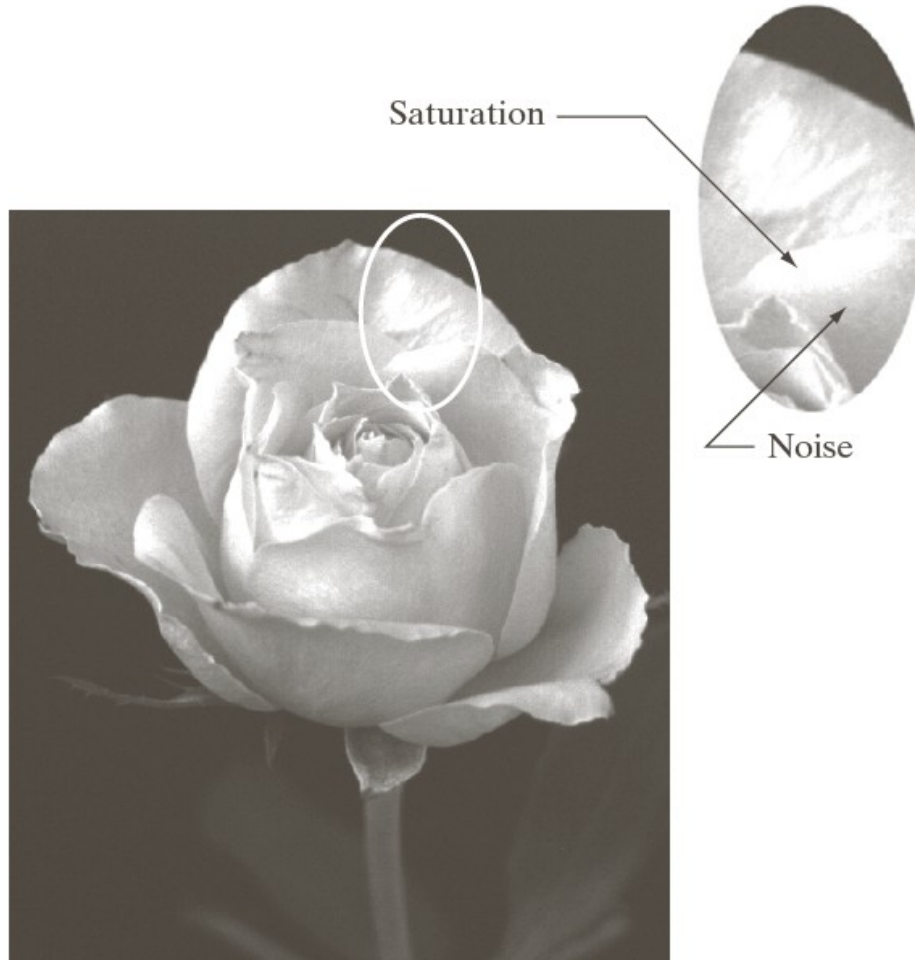
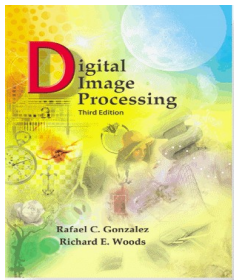

FIGURE 2.19 An image exhibiting saturation and noise. Saturation is the highest value beyond which all intensity levels are clipped (note how the entire saturated area has a high, *constant* intensity level). Noise in this case appears as a grainy texture pattern. Noise, especially in the darker regions of an image (e.g., the stem of the rose) masks the lowest detectable true intensity level.



Digital Image Processing, 3rd ed.

Gonzalez &

Woods

www.digitallimageprocessingplace.com

Chapter 2 Digital Image Fundamentals

TABLE 2.1

Number of storage bits for various values of N and k .

N/k	1 ($L = 2$)	2 ($L = 4$)	3 ($L = 8$)	4 ($L = 16$)	5 ($L = 32$)	6 ($L = 64$)	7 ($L = 128$)	8 ($L = 256$)
32	1,024	2,048	3,072	4,096	5,120	6,144	7,168	8,192
64	4,096	8,192	12,288	16,384	20,480	24,576	28,672	32,768
128	16,384	32,768	49,152	65,536	81,920	98,304	114,688	131,072
256	65,536	131,072	196,608	262,144	327,680	393,216	458,752	524,288
512	262,144	524,288	786,432	1,048,576	1,310,720	1,572,864	1,835,008	2,097,152
1024	1,048,576	2,097,152	3,145,728	4,194,304	5,242,880	6,291,456	7,340,032	8,388,608
2048	4,194,304	8,388,608	12,582,912	16,777,216	20,971,520	25,165,824	29,369,128	33,554,432
4096	16,777,216	33,554,432	50,331,648	67,108,864	83,886,080	100,663,296	117,440,512	134,217,728
8192	67,108,864	134,217,728	201,326,592	268,435,456	335,544,320	402,653,184	469,762,048	536,870,912

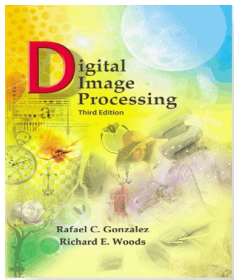

Digital Image Processing, 3rd ed.

Gonzalez &

Woods

www.ImageProcessingPlace.com

Chapter 2

Digital Image Fundamentals

- Spatial Resolution
 - Line pairs per unit distance
 - Chart with alternating black and white lines
 - Largest number of discernible line pairs in unit distance
 - dpi: dots / inch
 - Used in printing / publishing
 - Newspaper: 75 dpi
 - Magazine: 133 dpi
 - Glossy Brochure: 175 dpi
 - High Quality Book: 2400 dpi

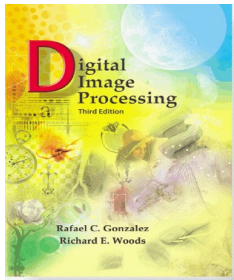

Digital Image Processing, 3rd ed.

Gonzalez &
Woods

www.ImageProcessingPlace.com

Chapter 2 Digital Image Fundamentals

@1250 dpi: 3692 X 2812

@72 dpi: 213 X 162



a b
c d

FIGURE 2.20 Typical effects of reducing spatial resolution. Images shown at: (a) 1250 dpi, (b) 300 dpi, (c) 150 dpi, and (d) 72 dpi. The thin black borders were added for clarity. They are not part of the data.

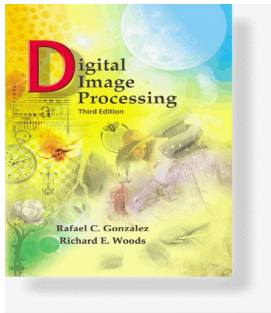

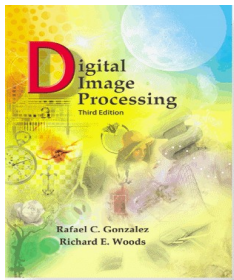

Digital Image Processing, 3rd ed.

Gonzalez &

Woods

www.ImageProcessingPlace.com

Chapter 2

Digital Image Fundamentals

- Intensity Resolution
 - Smallest discernible change in intensity level
 - Fixed by hardware
 - Typically 8 bits / 16 bits
 - False Contouring: Low # of intensity levels

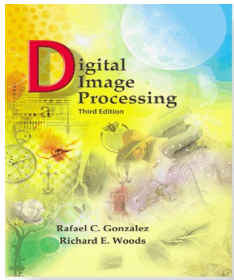

Digital Image Processing, 3rd ed.

Gonzalez &
Woods

www.ImageProcessingPlace.com

Chapter 2 Digital Image Fundamentals

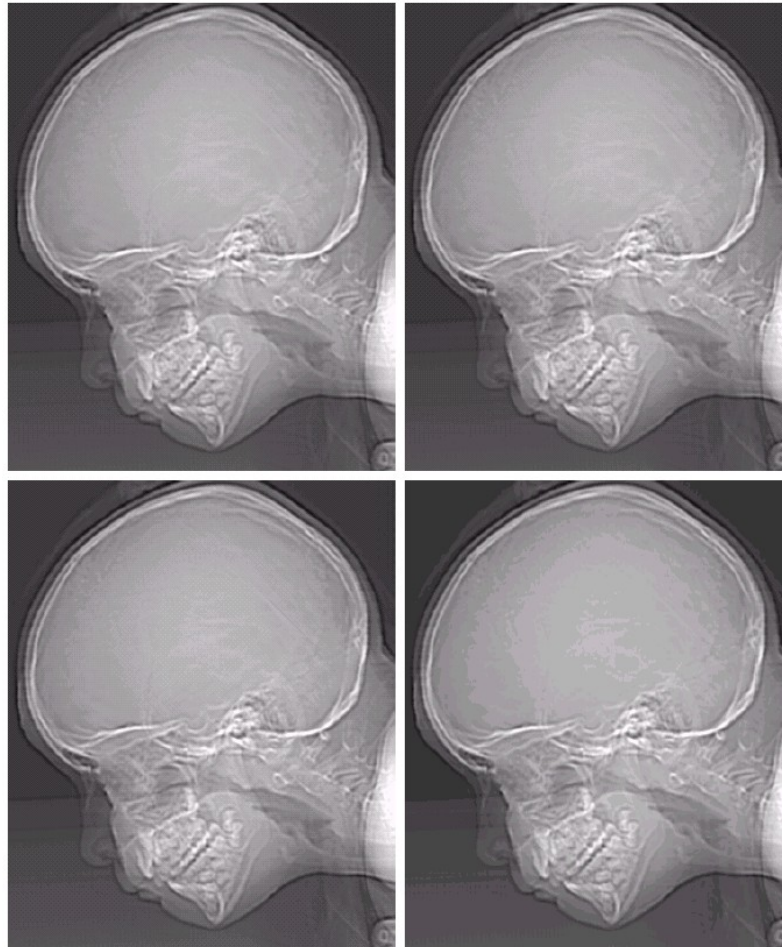

a b
c d

FIGURE 2.21
(a) 452×374 ,
256-level image.
(b)–(d) Image
displayed in 128,
64, and 32 gray
levels, while
keeping the
spatial resolution
constant.

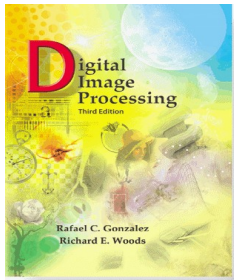

Digital Image Processing, 3rd ed.

Gonzalez &
Woods

www.ImageProcessingPlace.com

Chapter 2 Digital Image Fundamentals

e f
g h

FIGURE 2.21
(Continued)
(e)–(h) Image displayed in 16, 8, 4, and 2 gray levels. (Original courtesy of Dr. David R. Pickens, Department of Radiology & Radiological Sciences, Vanderbilt University Medical Center.)

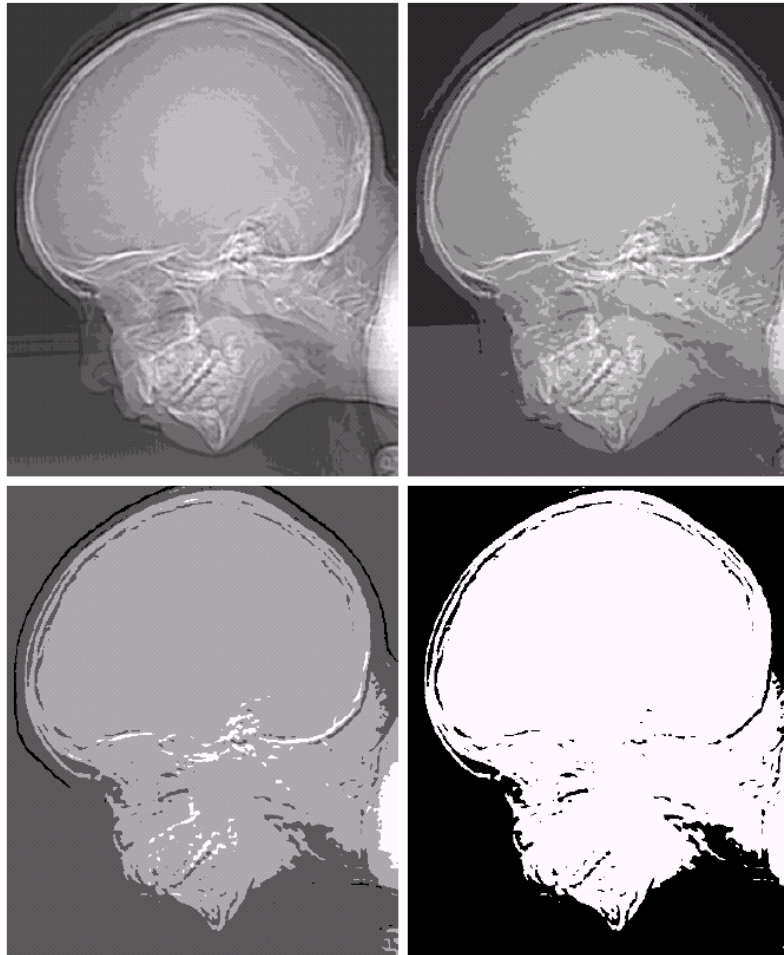

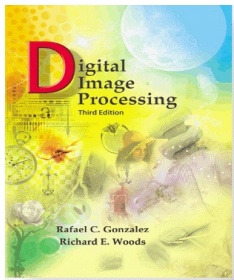

Digital Image Processing, 3rd ed.

Gonzalez &

Woods

www.ImageProcessingPlace.com

Chapter 2

Digital Image Fundamentals

- Spatial & Intensity Resolutions: Together
 - Vary N (Spatial Resolution $N \times N$) and k (Grayscale Resolution 2^k)
 - Subjects rank images at different $\langle N, k \rangle$ by their subjective quality
 - Experiments:
 - Nature depends on details in the image

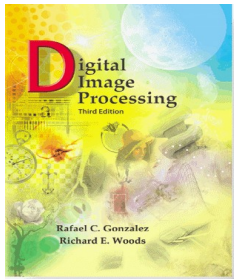

Digital Image Processing, 3rd ed.

Gonzalez &
Woods

www.ImageProcessingPlace.com

Chapter 2 Digital Image Fundamentals



a b c

FIGURE 2.22 (a) Image with a low level of detail. (b) Image with a medium level of detail. (c) Image with a relatively large amount of detail. (Image (b) courtesy of the Massachusetts Institute of Technology.)

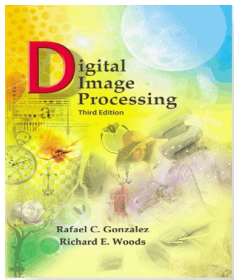

Digital Image Processing, 3rd ed.

Gonzalez &

Woods

www.ImageProcessingPlace.com

Chapter 2

Digital Image Fundamentals

- Isopreference Curves on N-k Plane
 - Points having same subjective quality
 - I-p Curves shifts right & upward
 - Becomes more vertical to left with details in image

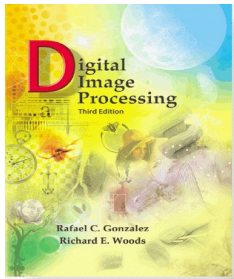

Digital Image Processing, 3rd ed.

Gonzalez &
Woods

www.ImageProcessingPlace.com

Chapter 2 Digital Image Fundamentals

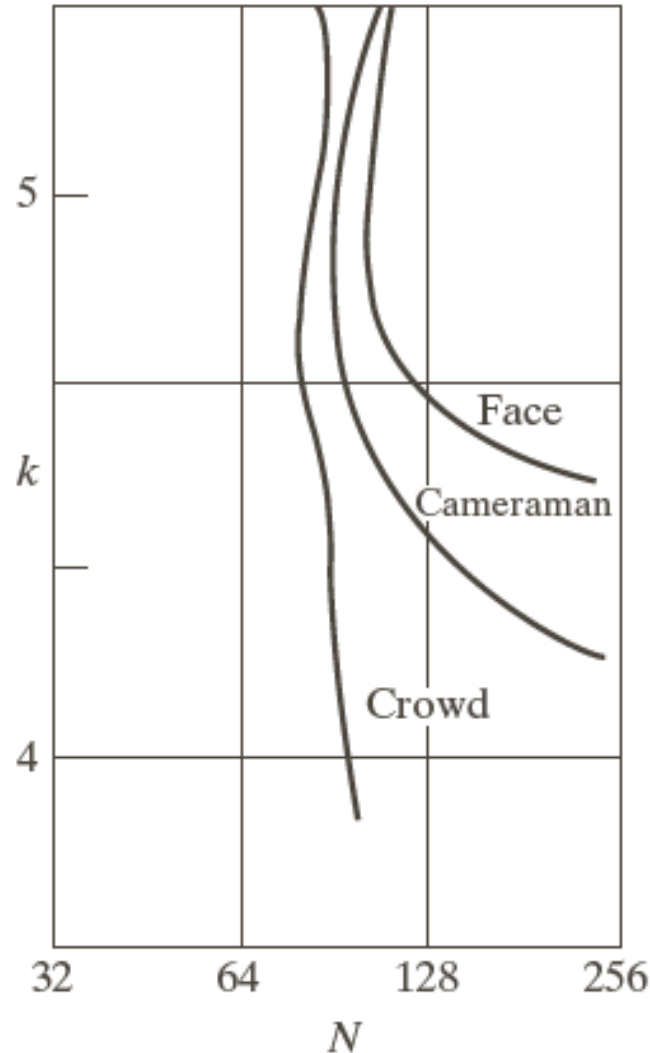
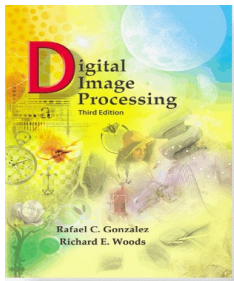

FIGURE 2.23
Typical
isopreference
curves for the
three types of
images in
Fig. 2.22.



Digital Image Processing, 3rd ed.

Gonzalez &

Woods

www.ImageProcessingPlace.com

Chapter 2

Digital Image Fundamentals

- **Interpolation:** Using known data to estimate values at unknown locations.
- Image Interpolation (Tool)
 - Zooming
 - Shrinking
 - Rotating
 - Geometric Correction
- Zooming & Shrinking
 - Re-sampling

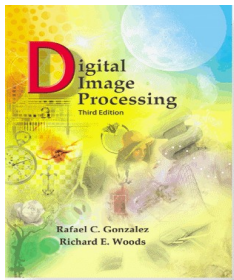

Digital Image Processing, 3rd ed.

Gonzalez &

Woods

www.ImageProcessingPlace.com

Chapter 2

Digital Image Fundamentals

- Enlargement by 1.5 times
 - Image is 500 X 500
 - Imaginary Array: 750 X 750 (same pixel spacing)
 - Shrink to fit the original image (reduced pixel spacing)
 - Set value from the closest pixel in original image
 - Expand it to the original expanded size
 - This is **Nearest Neighbor Interpolation**
 - Produces artifacts (distortion of straight edge)

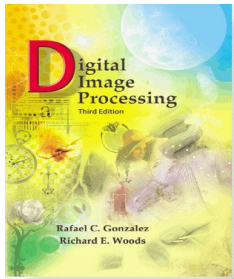

Digital Image Processing, 3rd ed.

Gonzalez &

Woods

www.ImageProcessingPlace.com

Chapter 2

Digital Image Fundamentals

• Nearest Neighbor Interpolation

– Induces Voronoi Diagram

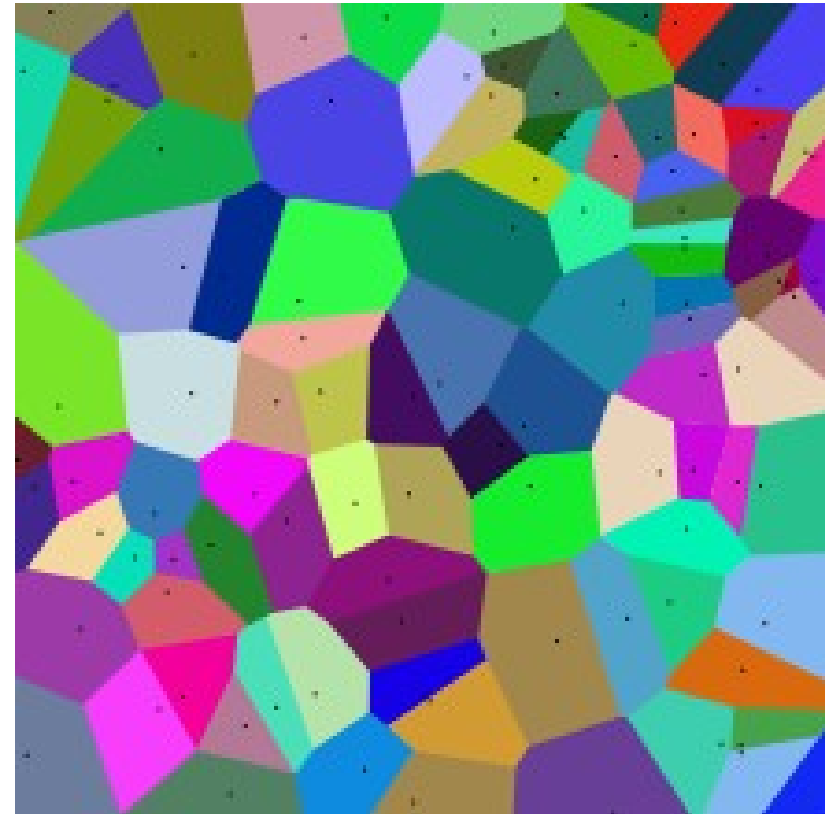
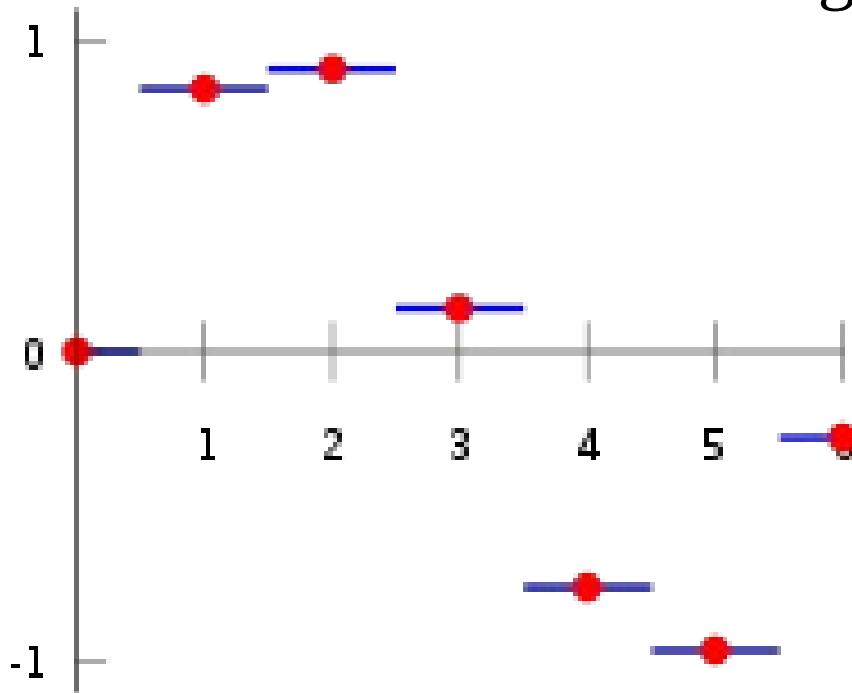

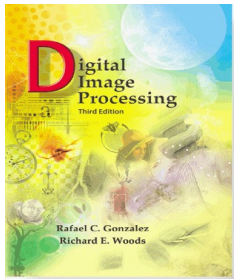

Digital Image Processing, 3rd ed.

Gonzalez &
Woods

www.dsp-processing.com

Chapter 2 Digital Image Fundamentals

• Bilinear Interpolation

- Use 4 nearest neighbor
- Solve for 4 coefficients
- $V(x,y) = ax+by+cxy+d$

$$f(R_1) \approx \frac{x_2 - x}{x_2 - x_1} f(Q_{11}) + \frac{x - x_1}{x_2 - x_1} f(Q_{21})$$

$$f(R_2) \approx \frac{x_2 - x}{x_2 - x_1} f(Q_{12}) + \frac{x - x_1}{x_2 - x_1} f(Q_{22})$$

$$f(P) \approx \frac{y_2 - y}{y_2 - y_1} f(R_1) + \frac{y - y_1}{y_2 - y_1} f(R_2).$$

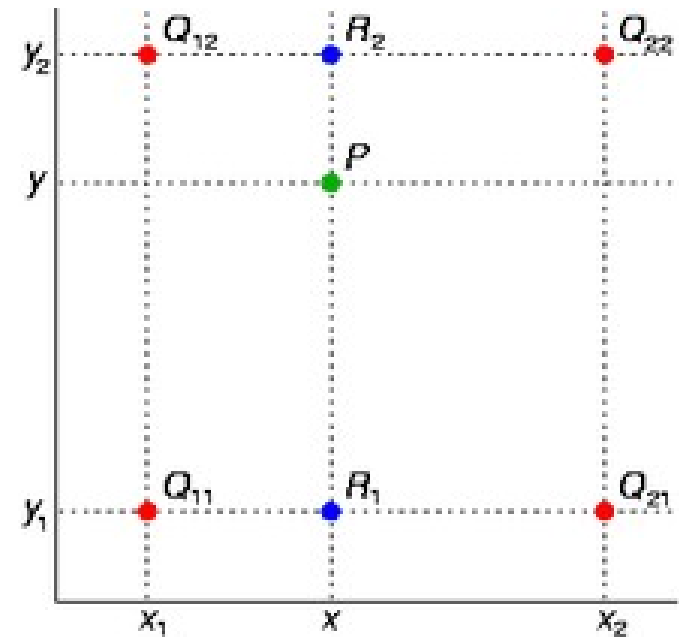

$$\begin{aligned} f(x, y) \approx & \frac{f(Q_{11})}{(x_2 - x_1)(y_2 - y_1)} (x_2 - x)(y_2 - y) \\ & + \frac{f(Q_{21})}{(x_2 - x_1)(y_2 - y_1)} (x - x_1)(y_2 - y) \\ & + \frac{f(Q_{12})}{(x_2 - x_1)(y_2 - y_1)} (x_2 - x)(y - y_1) \\ & + \frac{f(Q_{22})}{(x_2 - x_1)(y_2 - y_1)} (x - x_1)(y - y_1). \end{aligned}$$

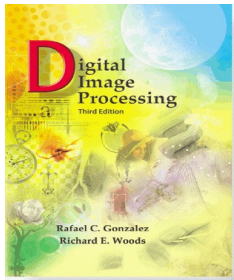

Digital Image Processing, 3rd ed.

Gonzalez &
Woods

www.ImageProcessingPlace.com

Chapter 2 Digital Image Fundamentals

• Bilinear Interpolation

$$f(x, y) \approx f(0,0)(1-x)(1-y) + f(1,0)x(1-y) + f(0,1)(1-x)y + f(1,1)xy.$$

$$f(x, y) \approx \begin{bmatrix} 1-x & x \end{bmatrix} \begin{bmatrix} f(0,0) & f(0,1) \\ f(1,0) & f(1,1) \end{bmatrix} \begin{bmatrix} 1-y \\ y \end{bmatrix}.$$

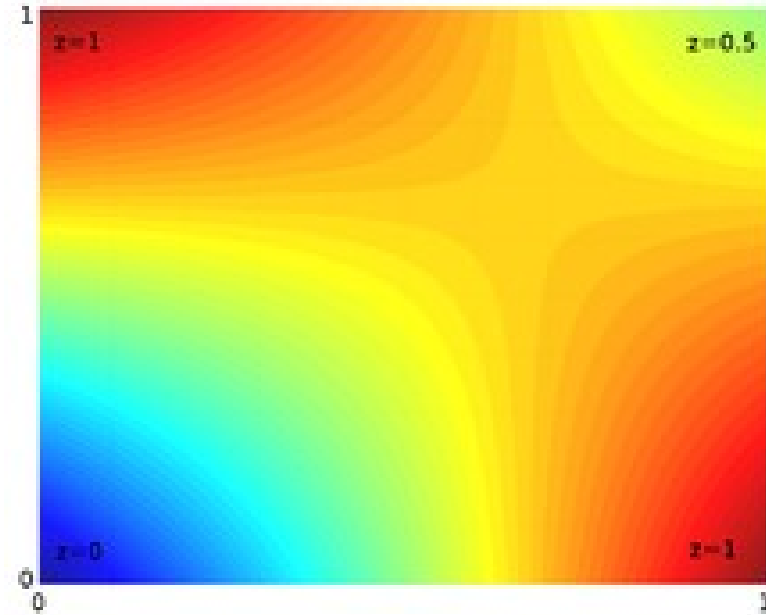
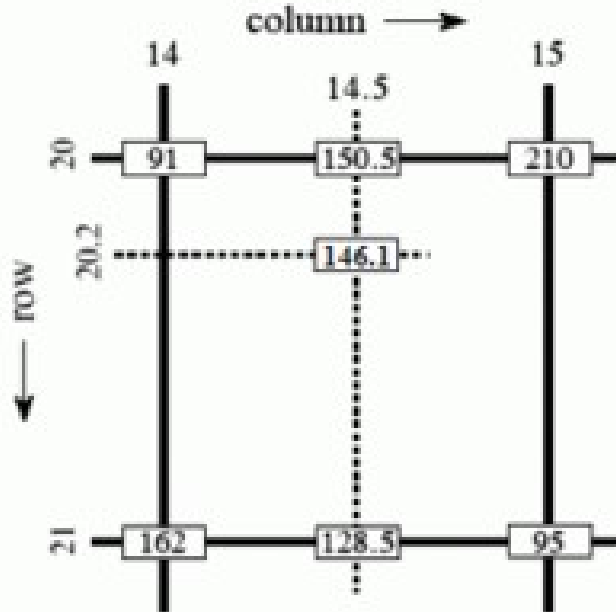

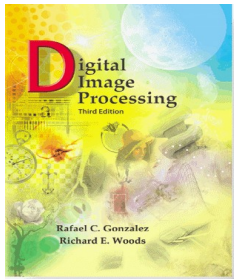

Digital Image Processing, 3rd ed.

Gonzalez &
Woods
www.ImageProcessingPlace.com

Chapter 2 Digital Image Fundamentals

• Bilinear Interpolation

1	3	6	1
3	3	1	7
8	1	8	7
6	1	1	1

Raster dataset

1	3	6	1
3	3	1	7
8	1	8	7
6	1	1	1

Nearest Neighbor
resampling

3	3	4	4
4	3	6	6
4	3	4	4
4	2	3	4

Bilinear
Interpolation

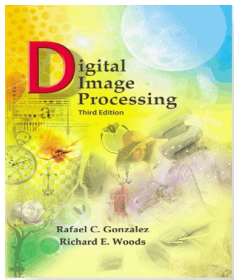

Digital Image Processing, 3rd ed.

Gonzalez &

Woods

www.ImageProcessingPlace.com

Chapter 2

Digital Image Fundamentals

- **Bicubic Interpolation (Discrete)**
 - Use 16 nearest neighbor
 - Solve for 16 coefficients
 - Used in Adobe Photoshop / Corel Photopaint

$$p(x, y) = \sum_{i=0}^3 \sum_{j=0}^3 a_{ij} x^i y^j.$$

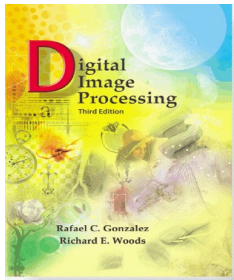

Digital Image Processing, 3rd ed.

Gonzalez &

Woods

www.ImageProcessingPlace.com

Chapter 2

Digital Image Fundamentals

- **Interpolation Comparative**

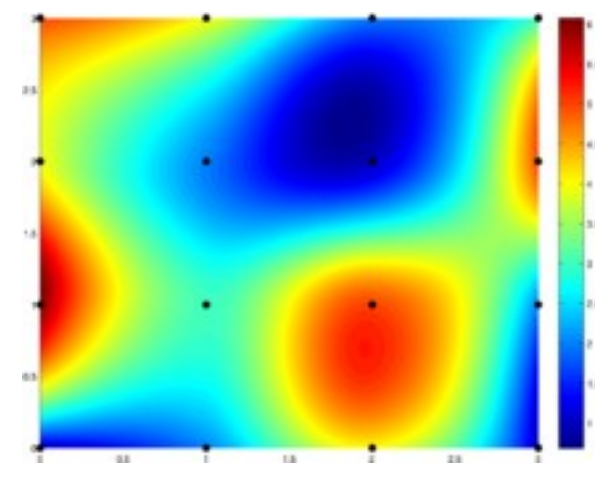
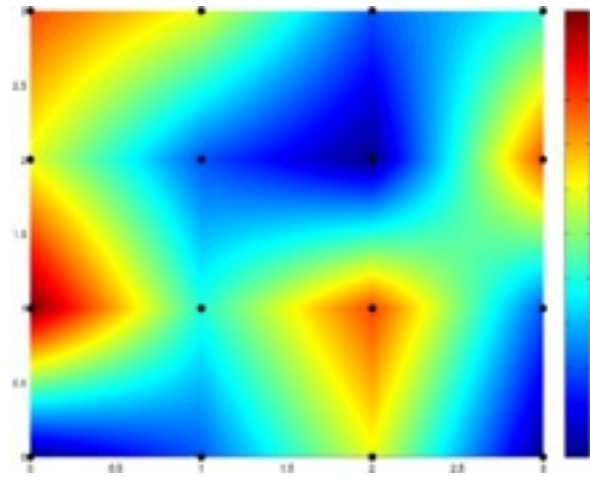
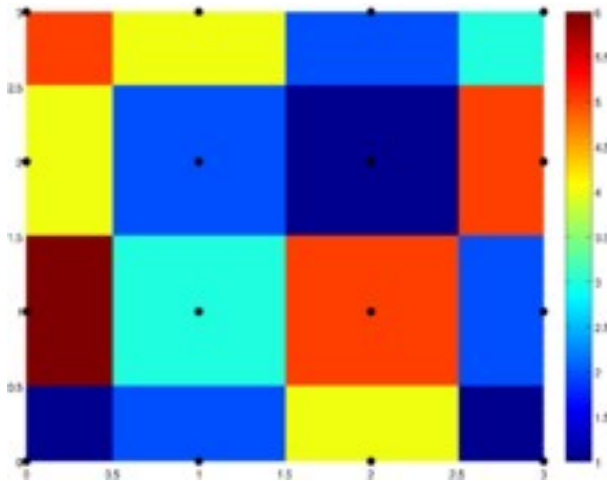

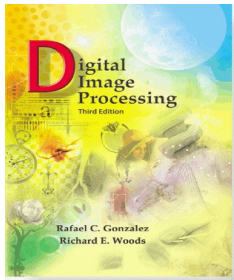

Digital Image Processing, 3rd ed.

Gonzalez &

Woods

www.ImageProcessingPlace.com

Chapter 2

Digital Image Fundamentals

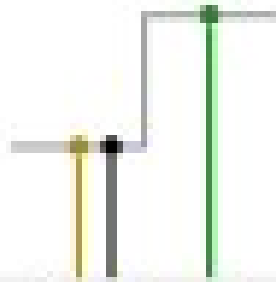

1D nearest-
neighbour

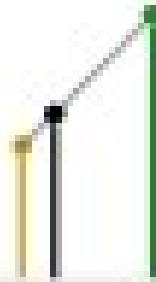

Linear

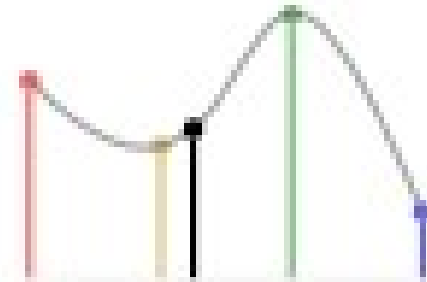

Cubic

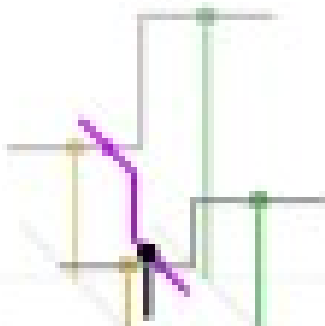

2D nearest-
neighbour

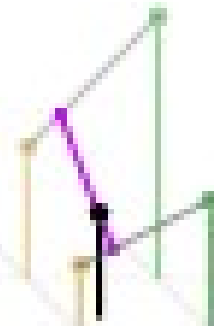

Bilinear

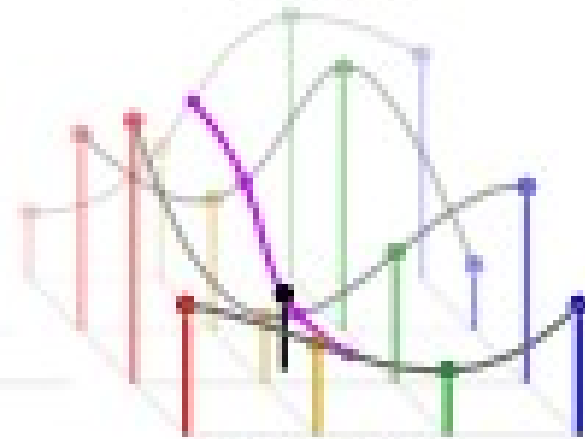

Bicubic

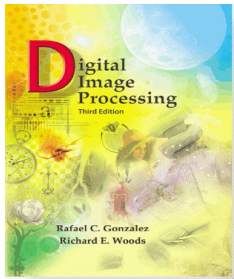

Digital Image Processing, 3rd ed.

Gonzalez &
Woods

www.dsp-processing.com

Chapter 2 Digital Image Fundamentals



a b c
d e f

FIGURE 2.24 (a) Image reduced to 72 dpi and zoomed back to its original size (3692×2812 pixels) using nearest neighbor interpolation. This figure is the same as Fig. 2.20(d). (b) Image shrunk and zoomed using bilinear interpolation. (c) Same as (b) but using bicubic interpolation. (d)–(f) Same sequence, but shrinking down to 150 dpi instead of 72 dpi [Fig. 2.24(d) is the same as Fig. 2.20(c)]. Compare Figs. 2.24(e) and (f), especially the latter, with the original image in Fig. 2.20(a).

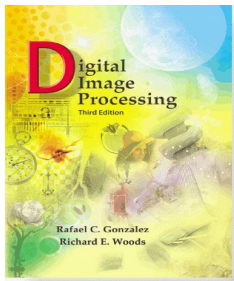

Digital Image Processing, 3rd ed.

Gonzalez &

Woods

www.ImageProcessingPlace.com

Chapter 2

Digital Image Fundamentals

1. Hsieh Hou and H. Andrews, “Cubic splines for image interpolation and digital filtering” IEEE Trans ASSP, Vol 26, Dec 1978.
2. J A Parker, R V Kenyon and Donald E Troxel, “Comparison of Interpolation methods for image resampling”, IEEE Trans Medical Image Processing, March 1983.
3. Robert G Keys, “Cubic convolution interpolation for Digital Image Processing”, IEEE Trans ASSP, 1981.

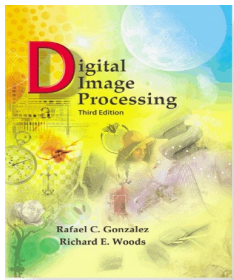

Digital Image Processing, 3rd ed.

Gonzalez &

Woods

www.ImageProcessingPlace.com

Chapter 2

Digital Image Fundamentals

Basic Relationships between Pixels

- Neighbors of a Pixel:
 - 4-neighbors $N_4(p)$: $\{(x+1,y), (x-1,y), (x,y+1), (x,y-1)\}$
 - Diagonal neighbors $N_D(p)$: $\{(x+1,y+1), (x-1,y+1), (x-1,y-1), (x+1,y-1)\}$
 - 8-neighbors: $N_8(p) = N_4(p) \cup N_D(p)$
- Adjacency:
 - 4-adjacency $(p,q) \in V$; $q \in N_4(p)$; V = set of intensity values
 - 8-adjacency $(p,q) \in V$; $q \in N_8(p)$
 - M-adjacency $(p,q) \in V$; $q \in N_4(p)$ OR $q \in N_D(p)$ and $N_4(p) \cap N_4(q) \neq \emptyset$

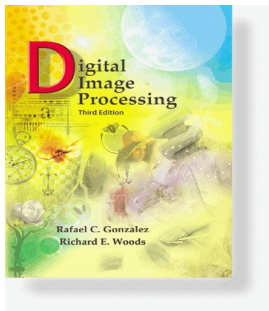

Digital Image Processing, 3rd ed.

Gonzalez &

Woods

www.dsp-processing.com

Chapter 2

Digital Image Fundamentals

Basic Relationships between Pixels

- Path
- Connected component
- Connected set (Region)
 - Adjacent
 - Disjoint
- Foreground & Background
- Boundary/border/contour : Global concept related to finite region
- Inner/Outer border
- Edge : pixels with derivative values that exceed a preset threshold. Thus, an edge is a “local” concept that is based on a measure of intensity-level discontinuity at a point.

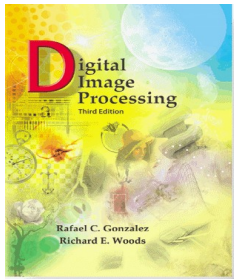

Digital Image Processing, 3rd ed.

Gonzalez &
Woods

www.ImageProcessingPlace.com

Chapter 2 Digital Image Fundamentals

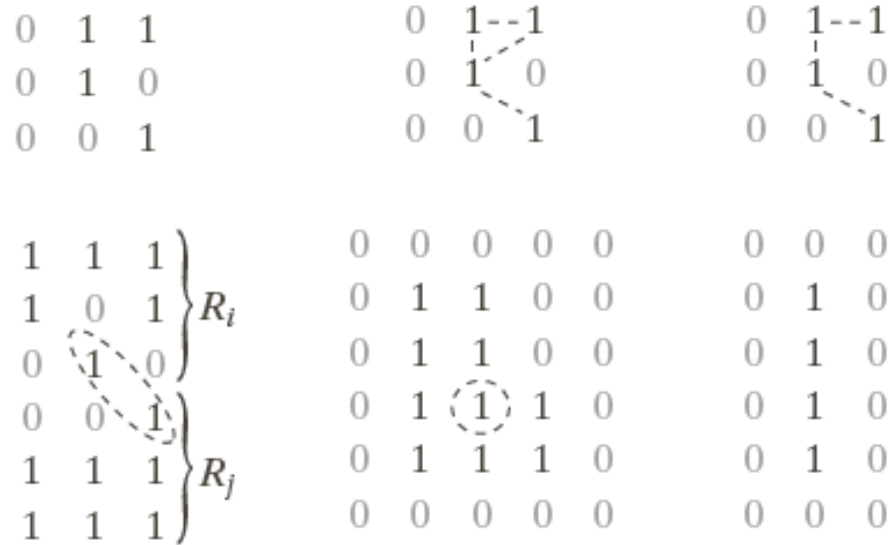

a	b	c
d	e	f

FIGURE 2.25 (a) An arrangement of pixels. (b) Pixels that are 8-adjacent (adjacency is shown by dashed lines; note the ambiguity). (c) m -adjacency. (d) Two regions that are adjacent if 8-adjacency is used. (e) The circled point is part of the boundary of the 1-valued pixels only if 8-adjacency between the region and background is used. (f) The inner boundary of the 1-valued region does not form a closed path, but its outer boundary does.

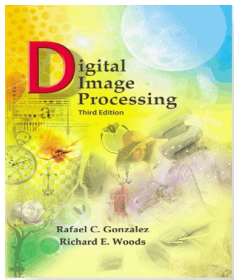

Digital Image Processing, 3rd ed.

Gonzalez &

Woods

www.digitallibraryprocessingPlace.com

Chapter 2

Digital Image Fundamentals

Distance Measures

Let $p(x,y)$, $q(s,t)$ and $z(v,w)$ are 3 pixels. D is a distance function If

a) $D(p,q) \geq 0$ ($D(p,q) = 0$, if $p = q$)

b) $D(p,q) = D(q,p)$

c) $D(p,z) \leq D(p,q) + D(q,z)$

• Eclidean Distance: $D_e(p, q) = [(x - s)^2 + (y - t)^2]^{1/2}$

• City block distance: $D_4(p, q) = |x - s| + |y - t|$

• Chessboard distance: $D_8(p, q) = \max(|x - s|, |y - t|)$

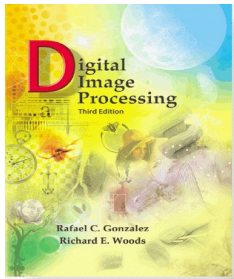

Digital Image Processing, 3rd ed.

Gonzalez &

Woods

www.ImageProcessingPlace.com

Chapter 2

Digital Image Fundamentals

City-Block Distance (D4 Distance)

```
      2
     2 1 2
    2 1 0 1 2
     2 1 2
      2
```

Chess-board Distance (D8 Distance)

```
  2  2  2  2  2
  2  1  1  1  2
  2  1  0  1  2
  2  1  1  1  2
  2  2  2  2  2
```

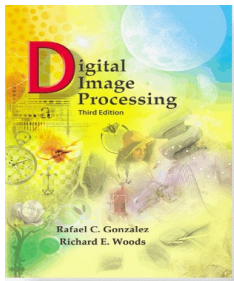

Digital Image Processing, 3rd ed.

Gonzalez &

Woods

www.ImageProcessingPlace.com

Chapter 2

Digital Image Fundamentals

Mathematical Tools used in DIP

Array versus Matrix operations

Linear vs Non-linear operations

Arithmetic operations

Set and Logical operations

Spatial operations

Vector and Matrix operations

Image transforms

Probabilistic methods

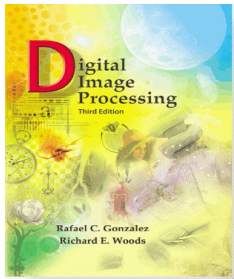

Digital Image Processing, 3rd ed.

Gonzalez &

Woods

www.ImageProcessingPlace.com

Chapter 2

Digital Image Fundamentals

Array vs Matrix Operations

$$\begin{bmatrix} a_{11} & a_{12} \\ a_{21} & a_{22} \end{bmatrix} \quad \begin{bmatrix} b_{11} & b_{12} \\ b_{21} & b_{22} \end{bmatrix}$$

Array product

$$\begin{bmatrix} a_{11} & a_{12} \\ a_{21} & a_{22} \end{bmatrix} \begin{bmatrix} b_{11} & b_{12} \\ b_{21} & b_{22} \end{bmatrix} = \begin{bmatrix} a_{11}b_{11} & a_{12}b_{12} \\ a_{21}b_{21} & a_{22}b_{22} \end{bmatrix}$$

Matrix product

$$\begin{bmatrix} a_{11} & a_{12} \\ a_{21} & a_{22} \end{bmatrix} \begin{bmatrix} b_{11} & b_{12} \\ b_{21} & b_{22} \end{bmatrix} = \begin{bmatrix} a_{11}b_{11} + a_{12}b_{21} & a_{11}b_{12} + a_{12}b_{22} \\ a_{21}b_{11} + a_{22}b_{21} & a_{21}b_{12} + a_{22}b_{22} \end{bmatrix}$$

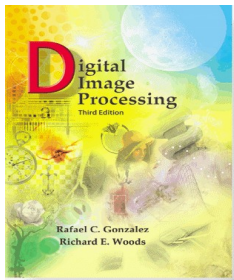

Digital Image Processing, 3rd ed.

Gonzalez &

Woods

www.dsp-processingPlace.com

Chapter 2

Digital Image Fundamentals

Linear vs Non-linear operations:

Linear operation: Sum operation over images

Non-linear operation: Max operation over images

$$H[f(x, y)] = g(x, y)$$

H is said to be linear operator if

$$\begin{aligned} H[a_i f_i(x, y) + a_j f_j(x, y)] &= a_i H[f_i(x, y)] + a_j H[f_j(x, y)] \\ &= a_i g_i(x, y) + a_j g_j(x, y) \end{aligned}$$

$$\begin{aligned} \sum [a f_1(x, y) + b f_2(x, y)] &= \sum a f_1(x, y) + \sum b f_2(x, y) \\ &= a \sum f_1(x, y) + b \sum f_2(x, y) \\ &= a g_1(x, y) + b g_2(x, y) \end{aligned}$$

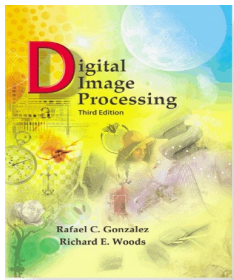

Digital Image Processing, 3rd ed.

Gonzalez &

Woods

www.ImageProcessingPlace.com

Chapter 2

Digital Image Fundamentals

Sum Operation:

$$f1 = \begin{bmatrix} 0 & 2 \\ 2 & 3 \end{bmatrix} \quad \text{and} \quad f2 = \begin{bmatrix} 6 & 5 \\ 4 & 7 \end{bmatrix}$$

$$\text{sum}\left\{(1) \begin{bmatrix} 0 & 2 \\ 2 & 3 \end{bmatrix} + (-1) \begin{bmatrix} 6 & 5 \\ 4 & 7 \end{bmatrix}\right\} = \text{sum}\left\{\begin{bmatrix} -6 & -3 \\ -2 & -4 \end{bmatrix}\right\} = -15$$

$$= (1) \text{sum}\left\{\begin{bmatrix} 0 & 2 \\ 2 & 3 \end{bmatrix}\right\} + (-1) \text{sum}\left\{\begin{bmatrix} 6 & 5 \\ 4 & 7 \end{bmatrix}\right\} = -15$$

Max Operation:

$$\text{max}\left\{(1) \begin{bmatrix} 0 & 2 \\ 2 & 3 \end{bmatrix} + (-1) \begin{bmatrix} 6 & 5 \\ 4 & 7 \end{bmatrix}\right\} = \text{max}\left\{\begin{bmatrix} -6 & -3 \\ -2 & -4 \end{bmatrix}\right\} = -2$$

$$(1) \text{max}\left\{\begin{bmatrix} 0 & 2 \\ 2 & 3 \end{bmatrix}\right\} + (-1) \text{max}\left\{\begin{bmatrix} 6 & 5 \\ 4 & 7 \end{bmatrix}\right\} = 3 - 7 = -4$$

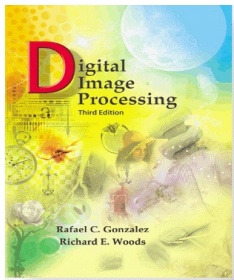

Digital Image Processing, 3rd ed.

Gonzalez &

Woods

www.ImageProcessingPlace.com

Chapter 2

Digital Image Fundamentals

Arithmetic Operations:

$$s(x,y) = f(x,y) + g(x,y)$$

$$d(x,y) = f(x,y) - g(x,y)$$

$$p(x,y) = f(x,y) \times g(x,y)$$

$$v(x,y) = f(x,y) \div g(x,y)$$

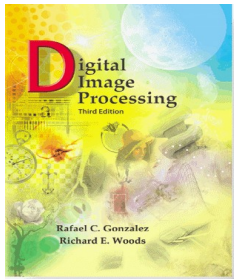

Digital Image Processing, 3rd ed.

Gonzalez &

Woods

www.ImageProcessingPlace.com

Chapter 2 Digital Image Fundamentals

Addition operation over Images

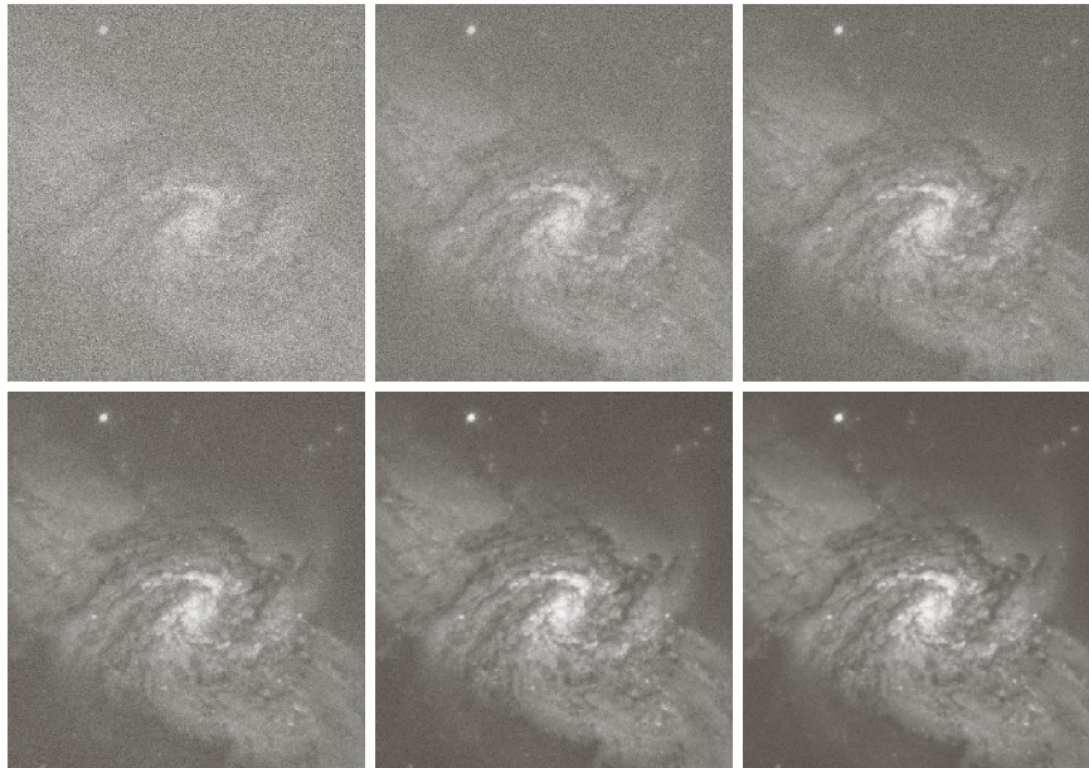

a b c
d e f

FIGURE 2.26 (a) Image of Galaxy Pair NGC 3314 corrupted by additive Gaussian noise. (b)–(f) Results of averaging 5, 10, 20, 50, and 100 noisy images, respectively. (Original image courtesy of NASA.)

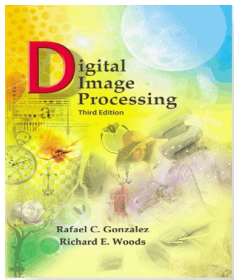

Digital Image Processing, 3rd ed.

Gonzalez &

Woods

www.ImageProcessingPlace.com

Chapter 2

Digital Image Fundamentals

$$g(x, y) = f(x, y) + \eta(x, y)$$

$$\bar{g}(x, y) = \frac{1}{K} \sum_{i=1}^K g_i(x, y)$$

$$E\{\bar{g}(x, y)\} = f(x, y)$$

$$\sigma_{\bar{g}(x, y)}^2 = \frac{1}{K} \sigma_{\eta(x, y)}^2$$

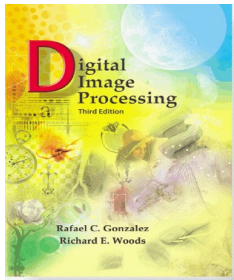

Digital Image Processing, 3rd ed.

Gonzalez &
Woods

www.ImageProcessingPlace.com

Chapter 2 Digital Image Fundamentals

Difference operation over Images

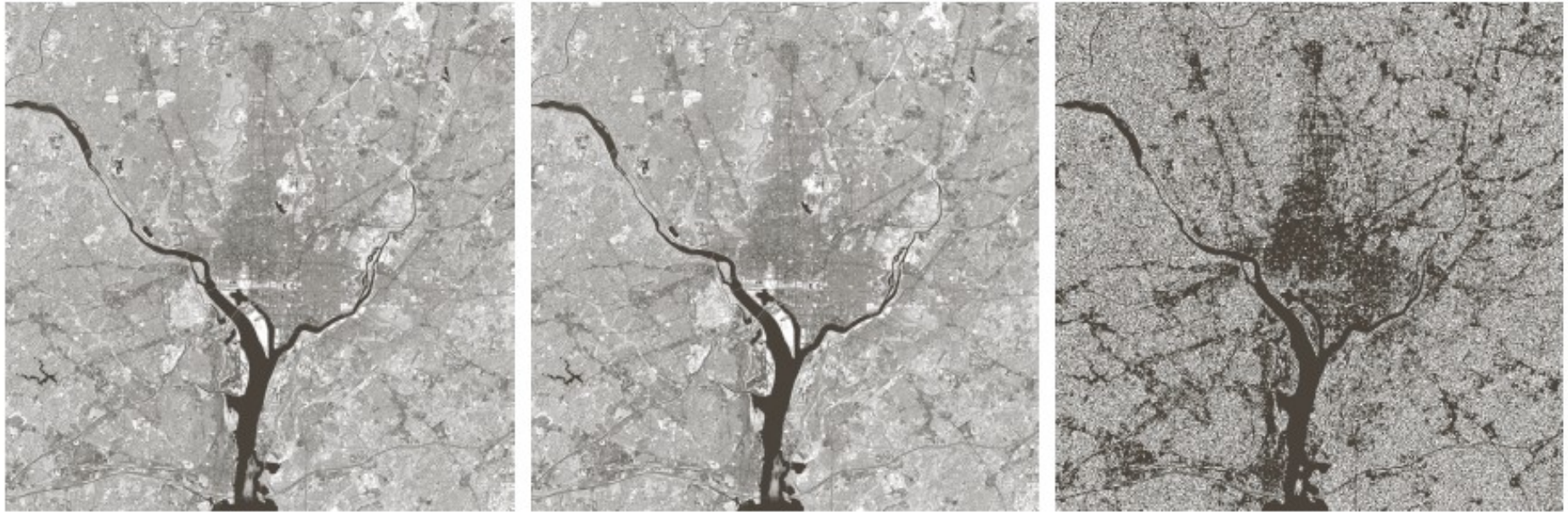

a b c

FIGURE 2.27 (a) Infrared image of the Washington, D.C. area. (b) Image obtained by setting to zero the least significant bit of every pixel in (a). (c) Difference of the two images, scaled to the range $[0, 255]$ for clarity.

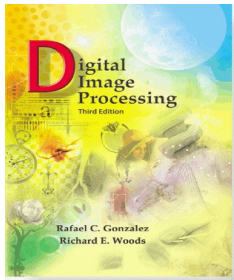

Digital Image Processing, 3rd ed.

Gonzalez &

Woods

www.ImageProcessingPlace.com

Chapter 2

Digital Image Fundamentals

Difference operation over Images (Cont..)



a b c

FIGURE 2.31 (a) Difference between the 930 dpi and 72 dpi images in Fig. 2.23. (b) Difference between the 930 dpi and 150 dpi images. (c) Difference between the 930 dpi and 300 dpi images.

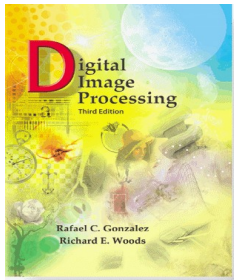

Digital Image Processing, 3rd ed.

Gonzalez &
Woods

www.ImageProcessingPlace.com

Chapter 2 Digital Image Fundamentals

Difference operation over Images (Cont..)

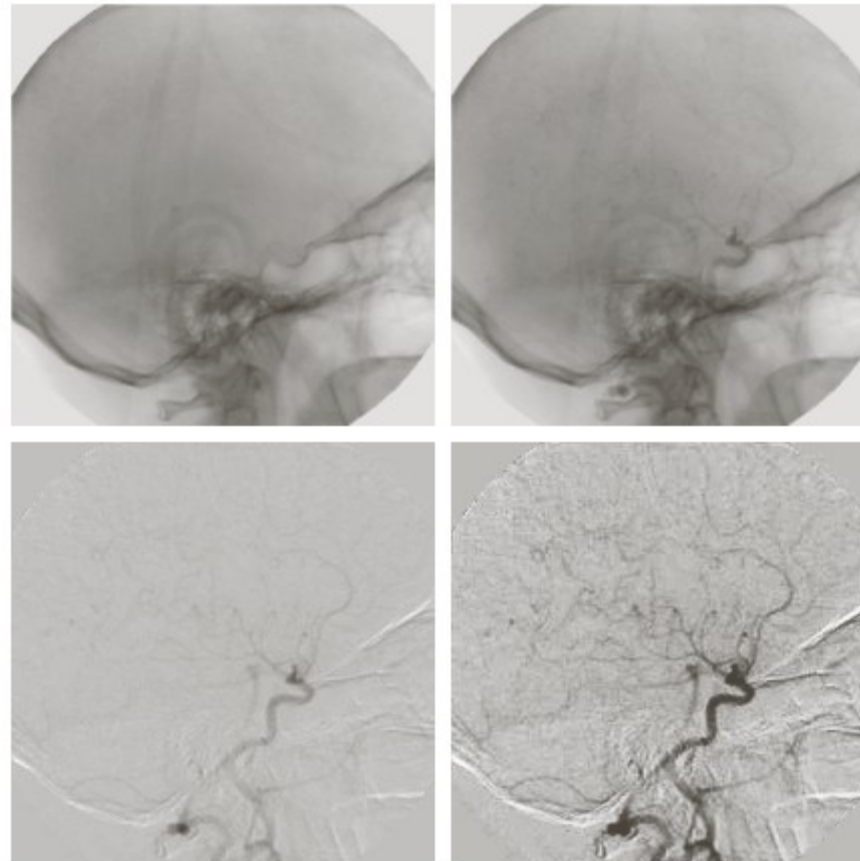

a b
c d

FIGURE 2.28

Digital subtraction angiography. (a) Mask image. (b) A live image. (c) Difference between (a) and (b). (d) Enhanced difference image. (Figures (a) and (b) courtesy of The Image Sciences Institute, University Medical Center, Utrecht, The Netherlands.)

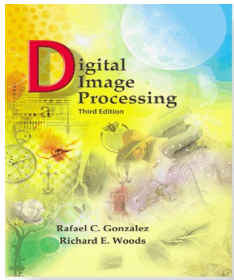

Digital Image Processing, 3rd ed.

Gonzalez &

Woods

www.ImageProcessingPlace.com

Chapter 2

Digital Image Fundamentals

Division operation over Images (Shading correction)

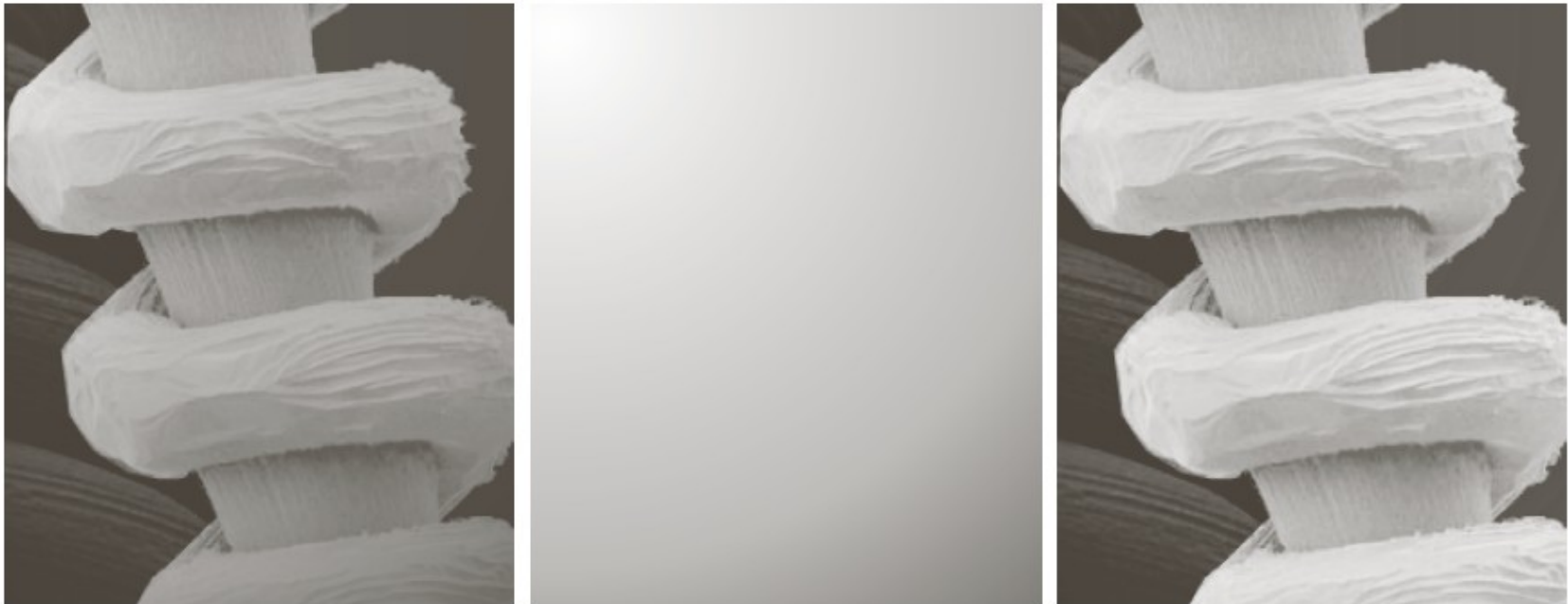

a b c

FIGURE 2.29 Shading correction. (a) Shaded SEM image of a tungsten filament and support, magnified approximately 130 times. (b) The shading pattern. (c) Product of (a) by the reciprocal of (b). (Original image courtesy of Mr. Michael Shaffer, Department of Geological Sciences, University of Oregon, Eugene.)

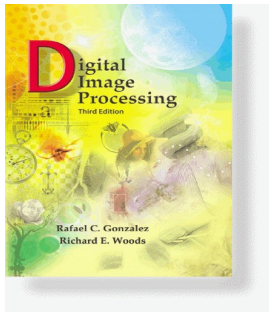

Digital Image Processing, 3rd ed.

Gonzalez &

Woods

www.ImageProcessingPlace.com

Chapter 2

Digital Image Fundamentals

Division operation over Images (Shading correction)



a b c

FIGURE 2.33 Shading correction. (a) Shaded test pattern. (b) Estimated shading pattern. (c) Product of (a) by the reciprocal of (b). (See Section 3.5 for a discussion of how (b) was estimated.)

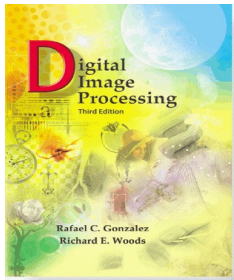

Digital Image Processing, 3rd ed.

Gonzalez &

Woods

www.ImageProcessingPlace.com

Chapter 2

Digital Image Fundamentals

Multiplication operation over Images (Masking/Region of Interest (ROI))



a b c

FIGURE 2.30 (a) Digital dental X-ray image. (b) ROI mask for isolating teeth with fillings (white corresponds to 1 and black corresponds to 0). (c) Product of (a) and (b).

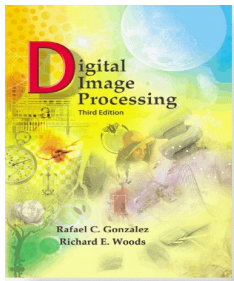

Digital Image Processing, 3rd ed.

Gonzalez &

Woods

www.ImageProcessingPlace.com

Chapter 2

Digital Image Fundamentals

Intensity Corrections after Arithmetic operations:

Addition: 0 to 510

Subtraction: -255 to 255

$$f_m = f - \min(f)$$

$$f_s = K \left[\frac{f_m}{\max(f_m)} \right]$$

Division: Small number to be added to the pixels of divisor image to avoid division by zero

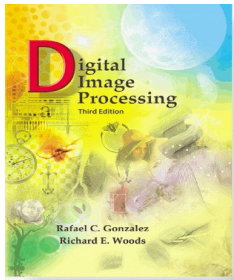

Digital Image Processing, 3rd ed.

Gonzalez &
Woods

www.ImageProcessingPlace.com

Chapter 2 Digital Image Fundamentals

Set operations over binary images

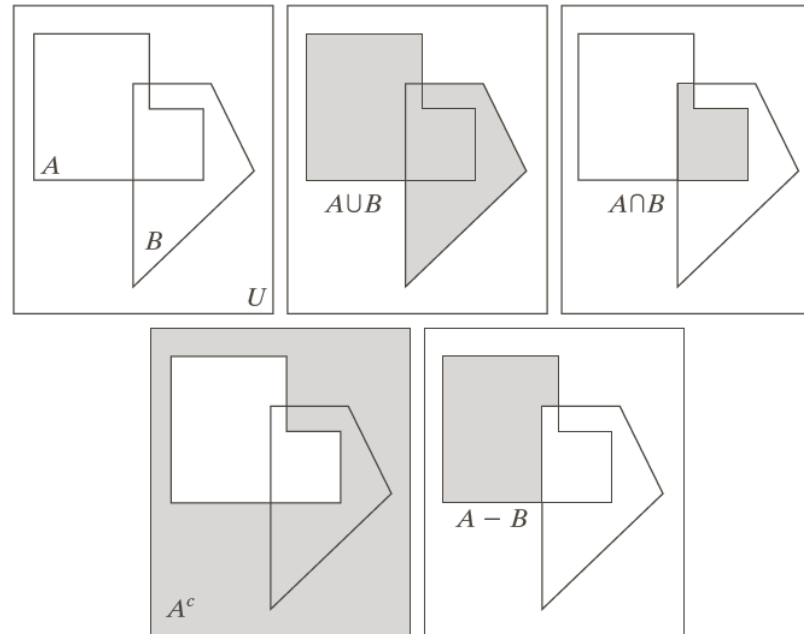

a	b	c
d	e	

FIGURE 2.31

(a) Two sets of coordinates, A and B , in 2-D space. (b) The union of A and B . (c) The intersection of A and B . (d) The complement of A . (e) The difference between A and B . In (b)–(e) the shaded areas represent the member of the set operation indicated.

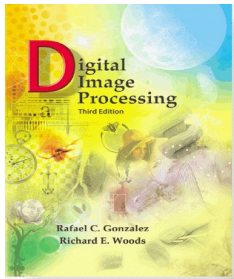

Digital Image Processing, 3rd ed.

Gonzalez &

Woods

www.ImageProcessingPlace.com

Chapter 2

Digital Image Fundamentals

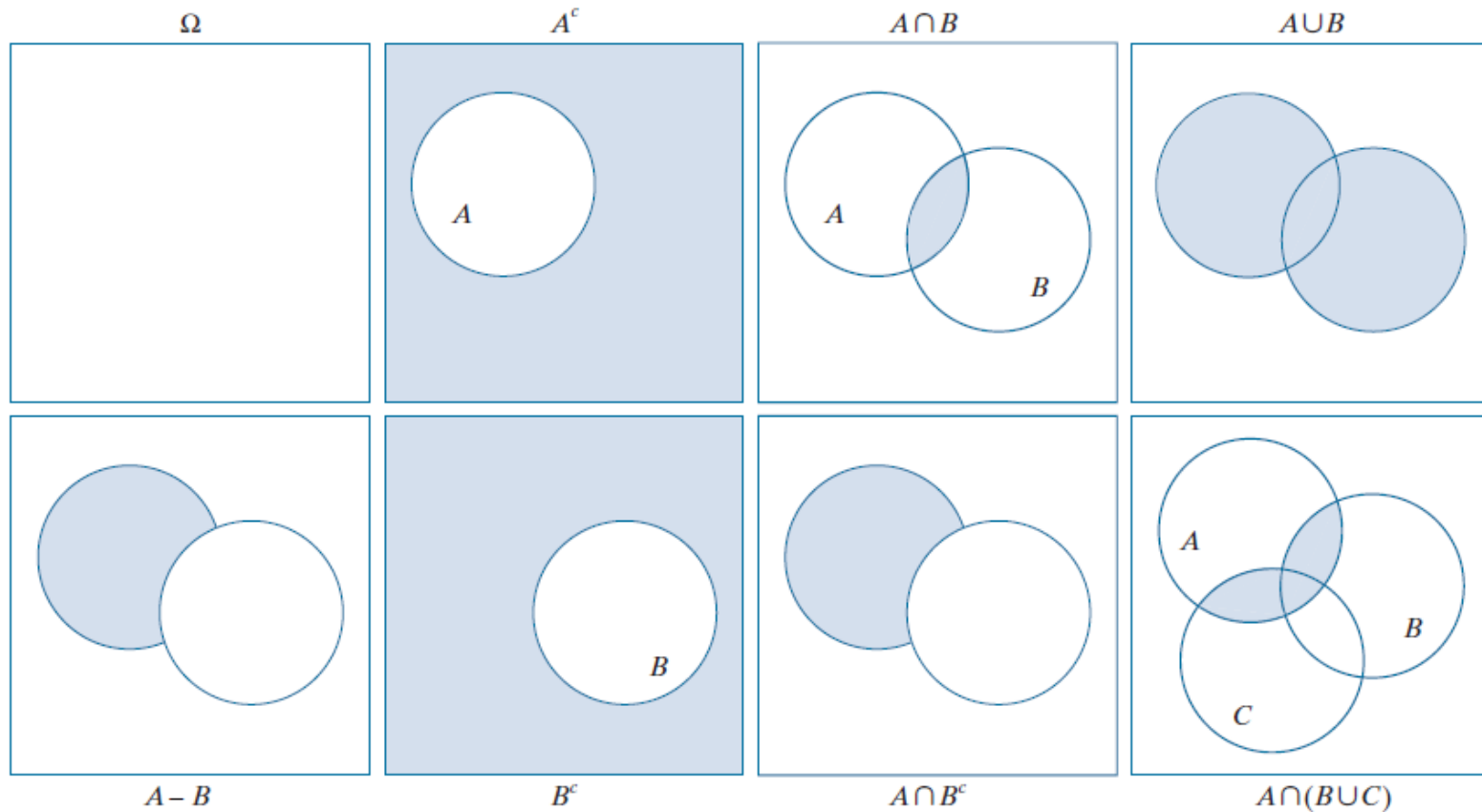

a	b	c	d
e	f	g	h

FIGURE 2.35 Venn diagrams corresponding to some of the set operations in Table 2.1. The results of the operations, such as A^c , are shown shaded. Figures (e) and (g) are the same, proving via Venn diagrams that $A - B = A \cap B^c$ [see Eq. (2-40)].

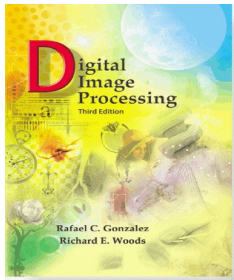

Digital Image Processing, 3rd ed.

Gonzalez &
Woods

www.ImageProcessingPlace.com

Chapter 2 Digital Image Fundamentals

Set operations over Gray scale Images

$$A^c = \{(x, y, K - z) \mid (x, y, z) \in A\}$$

$$A^c = \{(x, y, 255 - z) \mid (x, y, z) \in A\}$$

$$A \cup B = \left\{ \max_z(a, b) \mid a \in A, b \in B \right\}$$

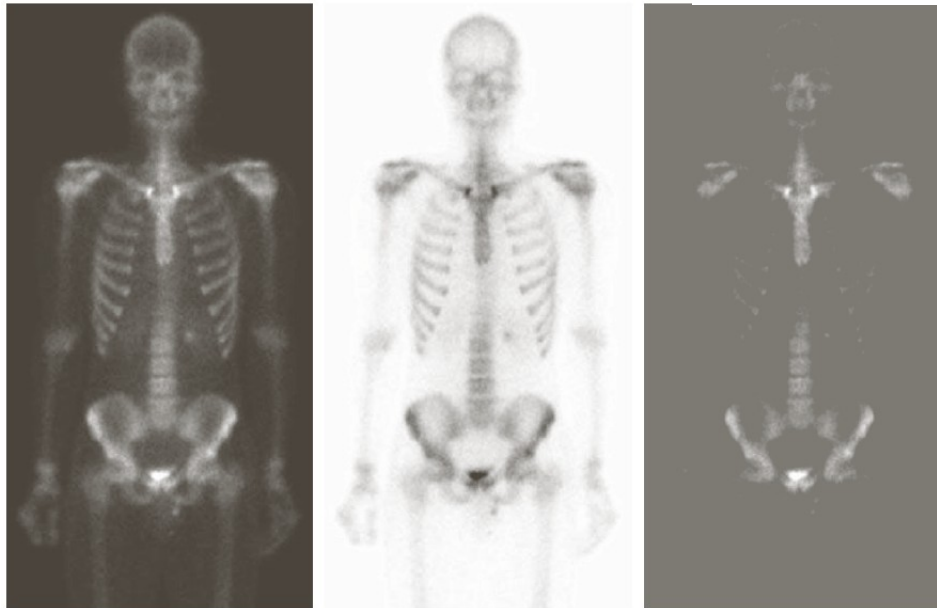

a b c

FIGURE 2.32 Set operations involving gray-scale images. (a) Original image. (b) Image negative obtained using set complementation. (c) The union of (a) and a constant image. (Original image courtesy of G.E. Medical Systems.)

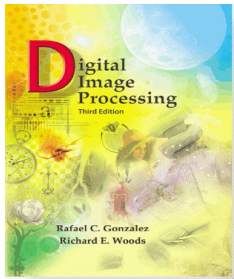

Digital Image Processing, 3rd ed.

Gonzalez &
Woods

www.ImageProcessingPlace.com

Chapter 2 Digital Image Fundamentals

Logical operations over Binary Images

a	b	$a \text{ AND } b$	$a \text{ OR } b$	$\text{NOT}(a)$
0	0	0	0	1
0	1	0	1	1
1	0	0	1	0
1	1	1	1	0

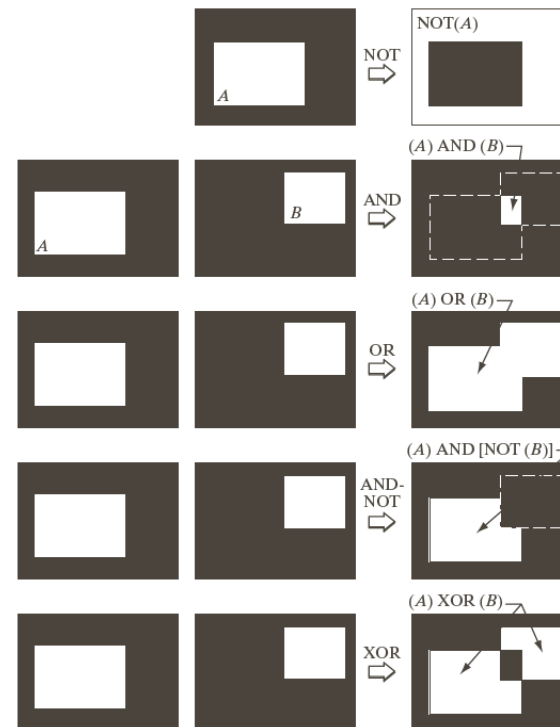
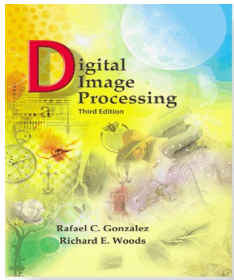

FIGURE 2.33 Illustration of logical operations involving foreground (white) pixels. Black represents binary 0s and white binary 1s. The dashed lines are shown for reference only. They are not part of the result.



Digital Image Processing, 3rd ed.

Gonzalez &
Woods

www.ImageProcessingPlace.com

Chapter 2 Digital Image Fundamentals

Spatial operation over Images

Single pixel operations

Neighborhood operations

Geometric transformations

$$s = T(z)$$

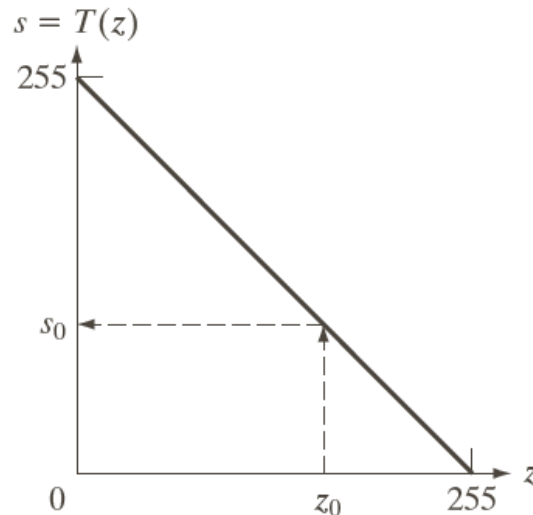
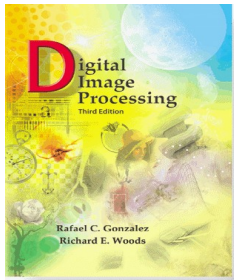

FIGURE 2.34 Intensity transformation function used to obtain the negative of an 8-bit image. The dashed arrows show transformation of an arbitrary input intensity value z_0 into its corresponding output value s_0 .



Digital Image Processing, 3rd ed.

Gonzalez &
Woods

www.ImageProcessingPlace.com

Chapter 2 Digital Image Fundamentals

Spatial operation over Images: Neighbourhood operations

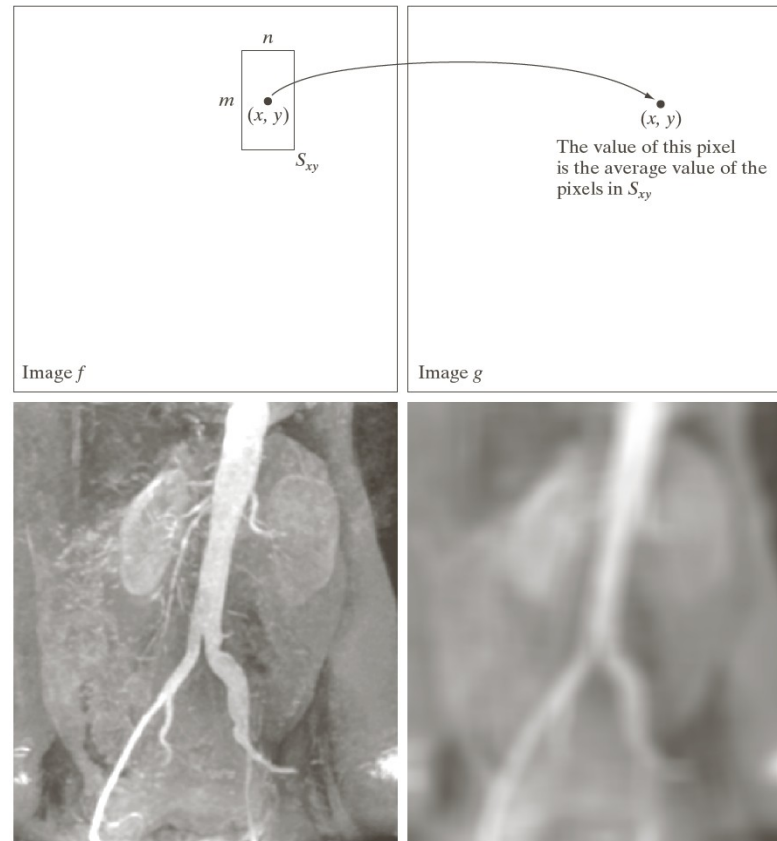
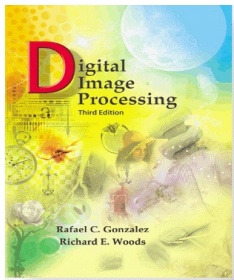

FIGURE 2.35

Local averaging using neighborhood processing. The procedure is illustrated in (a) and (b) for a rectangular neighborhood. (c) The aortic angiogram discussed in Section 1.3.2. (d) The result of using Eq. (2.6-21) with $m = n = 41$. The images are of size 790×686 pixels.



Digital Image Processing, 3rd ed.

Gonzalez &

Woods

www.ImageProcessingPlace.com

Chapter 2

Digital Image Fundamentals

Geometric transformations over Images

$$\begin{bmatrix} x' \\ y' \end{bmatrix} = T \begin{bmatrix} x \\ y \end{bmatrix} = \begin{bmatrix} t_{11} & t_{12} \\ t_{21} & t_{22} \end{bmatrix} \begin{bmatrix} x \\ y \end{bmatrix}$$

$$\begin{bmatrix} x' \\ y' \end{bmatrix} = T \begin{bmatrix} x \\ y \end{bmatrix} = \begin{bmatrix} t_{11} & t_{12} \\ t_{21} & t_{22} \end{bmatrix} \begin{bmatrix} x \\ y \end{bmatrix} + \begin{bmatrix} t_x \\ t_y \end{bmatrix}$$

$$\begin{bmatrix} x' \\ y' \\ 1 \end{bmatrix} = \mathbf{A} \begin{bmatrix} x \\ y \\ 1 \end{bmatrix} = \begin{bmatrix} a_{11} & a_{12} & a_{13} \\ a_{21} & a_{22} & a_{23} \\ 0 & 0 & 1 \end{bmatrix} \begin{bmatrix} x \\ y \\ 1 \end{bmatrix}$$

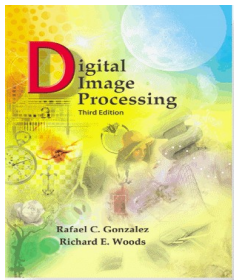

Transformation Name	Affine Matrix, A	Coordinate Equations	Example
Identity	$\begin{bmatrix} 1 & 0 & 0 \\ 0 & 1 & 0 \\ 0 & 0 & 1 \end{bmatrix}$	$\begin{aligned} x' &= x \\ y' &= y \end{aligned}$	
Scaling/Reflection (For reflection, set one scaling factor to -1 and the other to 0)	$\begin{bmatrix} c_x & 0 & 0 \\ 0 & c_y & 0 \\ 0 & 0 & 1 \end{bmatrix}$	$\begin{aligned} x' &= c_x x \\ y' &= c_y y \end{aligned}$	
Rotation (about the origin)	$\begin{bmatrix} \cos \theta & -\sin \theta & 0 \\ \sin \theta & \cos \theta & 0 \\ 0 & 0 & 1 \end{bmatrix}$	$\begin{aligned} x' &= x \cos \theta - y \sin \theta \\ y' &= x \sin \theta + y \cos \theta \end{aligned}$	
Translation	$\begin{bmatrix} 1 & 0 & t_x \\ 0 & 1 & t_y \\ 0 & 0 & 1 \end{bmatrix}$	$\begin{aligned} x' &= x + t_x \\ y' &= y + t_y \end{aligned}$	
Shear (vertical)	$\begin{bmatrix} 1 & s_v & 0 \\ 0 & 1 & 0 \\ 0 & 0 & 1 \end{bmatrix}$	$\begin{aligned} x' &= x + s_v y \\ y' &= y \end{aligned}$	
Shear (horizontal)	$\begin{bmatrix} 1 & 0 & 0 \\ s_h & 1 & 0 \\ 0 & 0 & 1 \end{bmatrix}$	$\begin{aligned} x' &= x \\ y' &= s_h x + y \end{aligned}$	

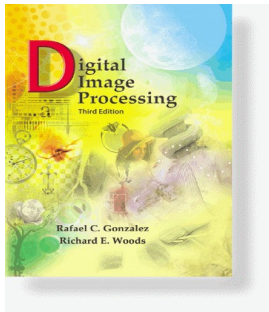

Digital Image Processing, 3rd ed.

Gonzalez &
Woods

www.ImageProcessingPlace.com

Chapter 2 Digital Image Fundamentals

Image Rotation



a b c d

FIGURE 2.36 (a) A 300 dpi image of the letter T. (b) Image rotated 21° clockwise using nearest neighbor interpolation to assign intensity values to the spatially transformed pixels. (c) Image rotated 21° using bilinear interpolation. (d) Image rotated 21° using bicubic interpolation. The enlarged sections show edge detail for the three interpolation approaches.

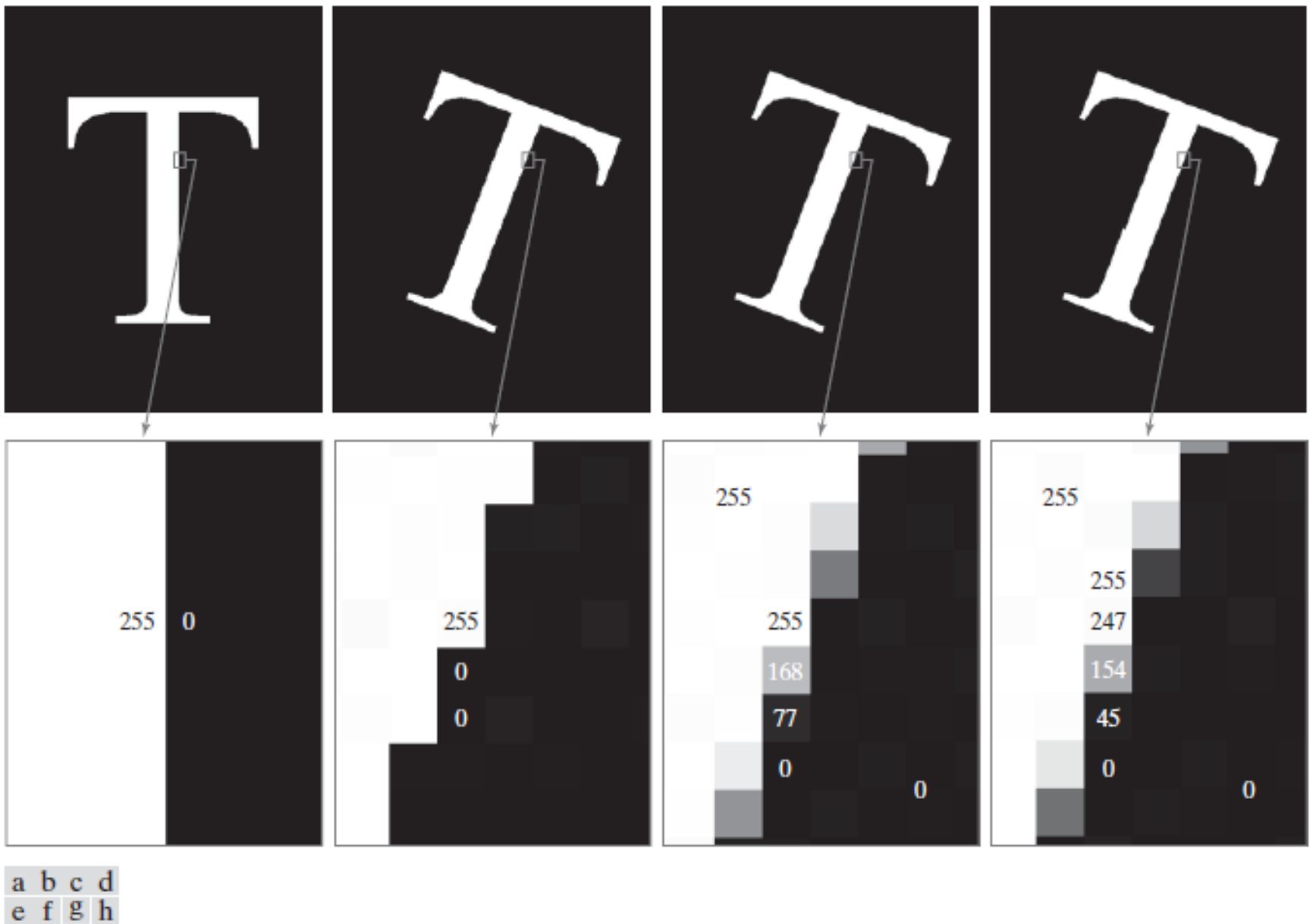
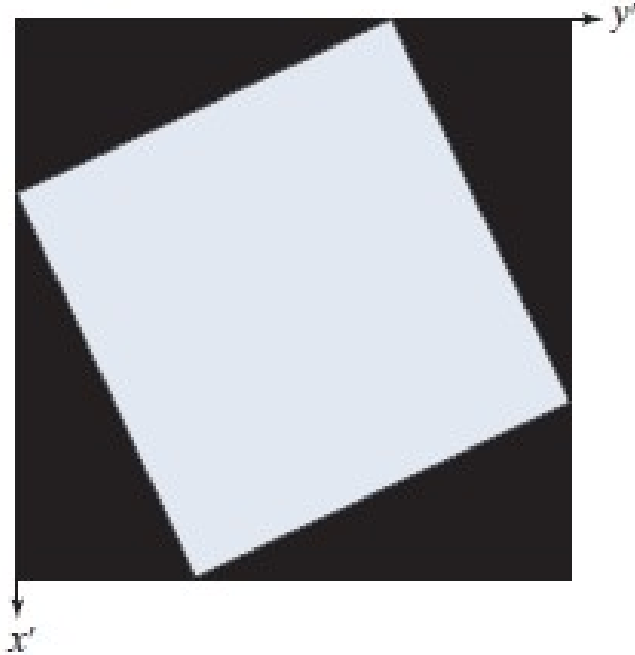
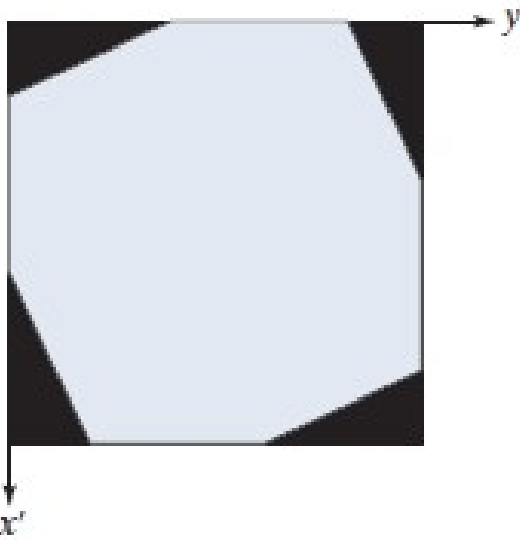
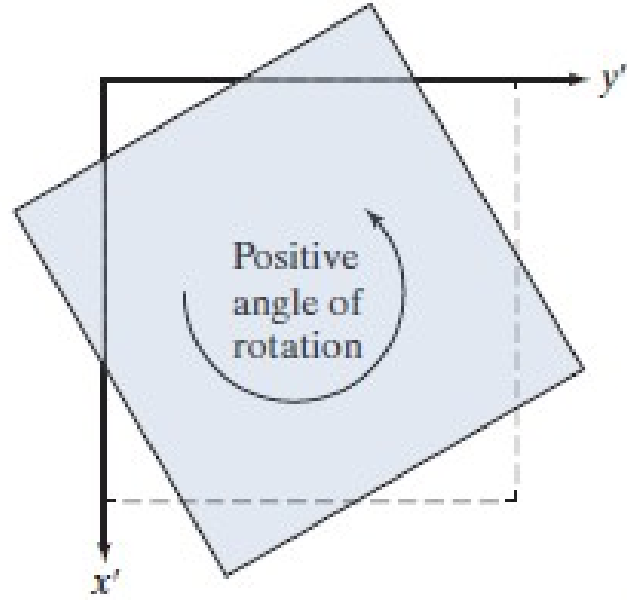
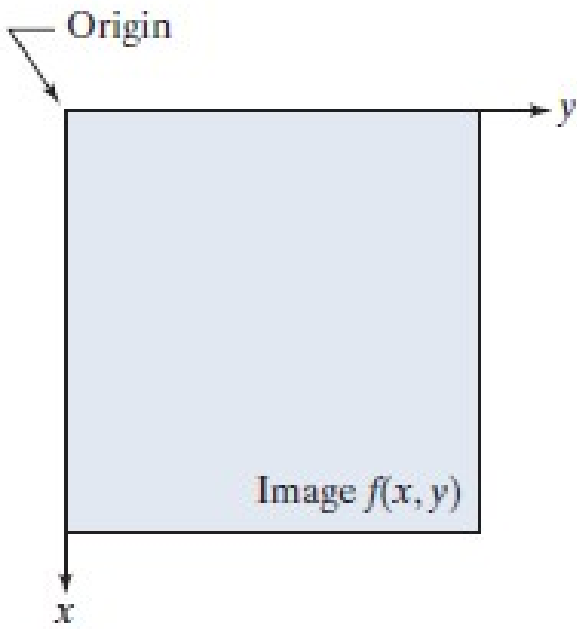

FIGURE 2.40 (a) A 541×421 image of the letter T. (b) Image rotated -21° using nearest-neighbor interpolation for intensity assignments. (c) Image rotated -21° using bilinear interpolation. (d) Image rotated -21° using bicubic interpolation. (e)-(h) Zoomed sections (each square is one pixel, and the numbers shown are intensity values).

a	b
c	d

FIGURE 2.41

- (a) A digital image.
- (b) Rotated image (note the counterclockwise direction for a positive angle of rotation).
- (c) Rotated image cropped to fit the same area as the original image.
- (d) Image enlarged to accommodate the entire rotated image.



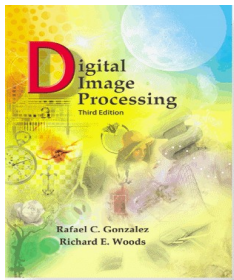

Digital Image Processing, 3rd ed.

Gonzalez &

Woods

www.ImageProcessingPlace.com

Chapter 2

Digital Image Fundamentals

Image Registration:

- Aligning the images taken from different sensors
- Aligning images taken from same sensor at different times
- Images taken from same sensor with different resolutions
- Tie-points (control points)
 - $x = c_1V + c_2W + c_3VW + c_4$
 - $y = c_5V + c_6W + c_7VW + c_8$
- Multiple quadrilateral regions
- Polynomials fitted by least squares algorithms

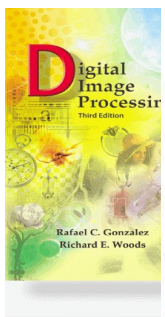

a b
c d

FIGURE 2.42
Image registration.
(a) Reference image. (b) Input (geometrically distorted image). Corresponding tie points are shown as small white squares near the corners.
(c) Registered (output) image (note the errors in the border).
(d) Difference between (a) and (c), showing more registration errors.

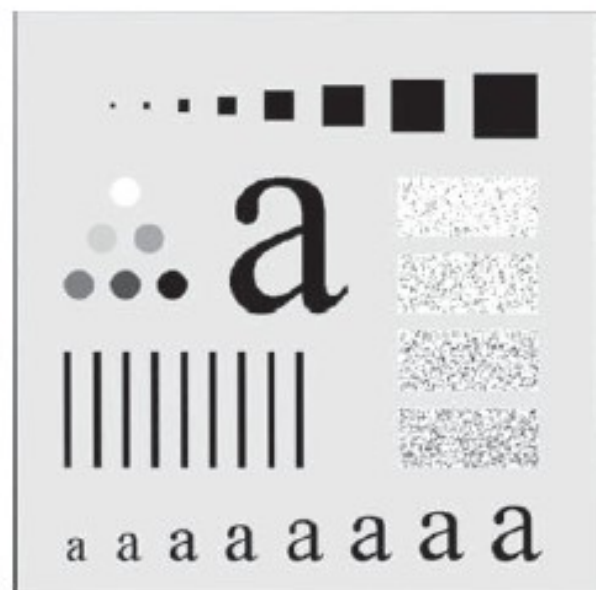
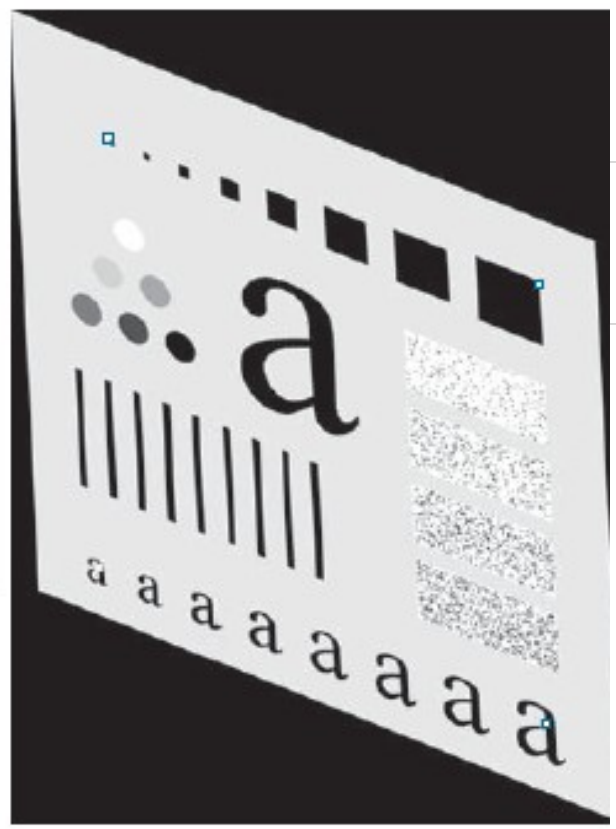
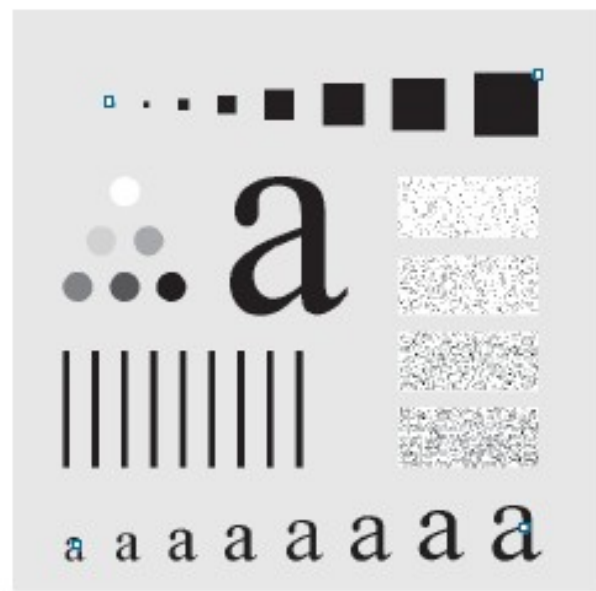
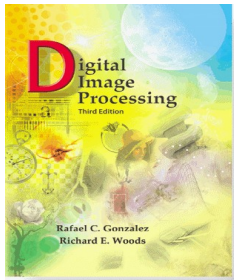

Image Registration



Digital Image Processing, 3rd ed.

Gonzalez &
Woods

www.ImageProcessingPlace.com

Chapter 2 Digital Image Fundamentals

Matrix & Vector Operations

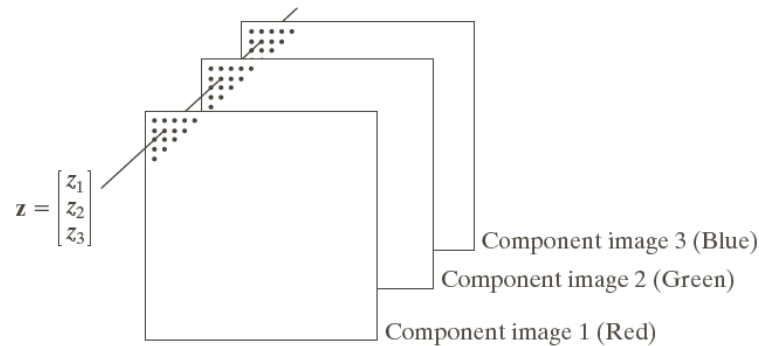
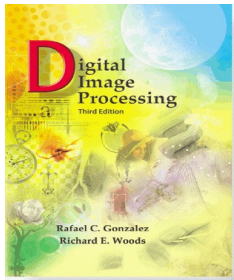

FIGURE 2.38
Formation of a
vector from
corresponding
pixel values in
three RGB
component
images.



Digital Image Processing, 3rd ed.

Gonzalez &
Woods

www.dsp-processing.com

Chapter 2 Digital Image Fundamentals

Image Transforms

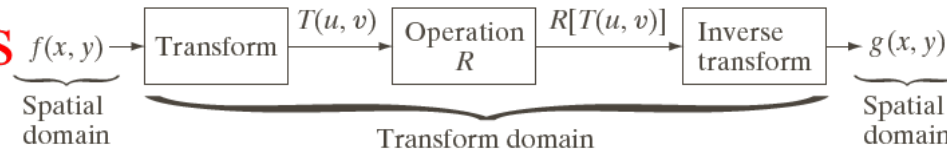

FIGURE 2.39
General approach
for operating in
the linear
transform
domain.

$$T(u, v) = \sum_{x=0}^{M-1} \sum_{y=0}^{N-1} f(x, y) r(x, y, u, v)$$

$$f(x, y) = \sum_{u=0}^{M-1} \sum_{v=0}^{N-1} T(u, v) s(x, y, u, v)$$

$f(x, y)$ = I/P image,

$r(x, y, u, v)$ = Forward transformation kernel

$s(x, y, u, v)$ = Reverse transformation kernel

$T(u, v)$ = Forward transformation of $f(x, y)$

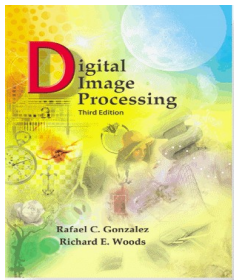

Digital Image Processing, 3rd ed.

Gonzalez &

Woods

www.ImageProcessingPlace.com

Chapter 2

Digital Image Fundamentals

2D-Discrete Fourier Transform pair

$$T(u, v) = \sum_{x=0}^{M-1} \sum_{y=0}^{N-1} f(x, y) e^{-j2\pi(ux/M + vy/N)}$$

$$f(x, y) = \frac{1}{MN} \sum_{u=0}^{M-1} \sum_{v=0}^{N-1} T(u, v) e^{j2\pi(ux/M + vy/N)}$$

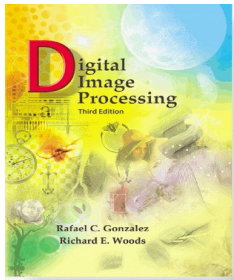

Digital Image Processing, 3rd ed.

Gonzalez &
Woods

www.ImageProcessingPlace.com

Chapter 2 Digital Image Fundamentals

Image enhancement through Fourier Transformation

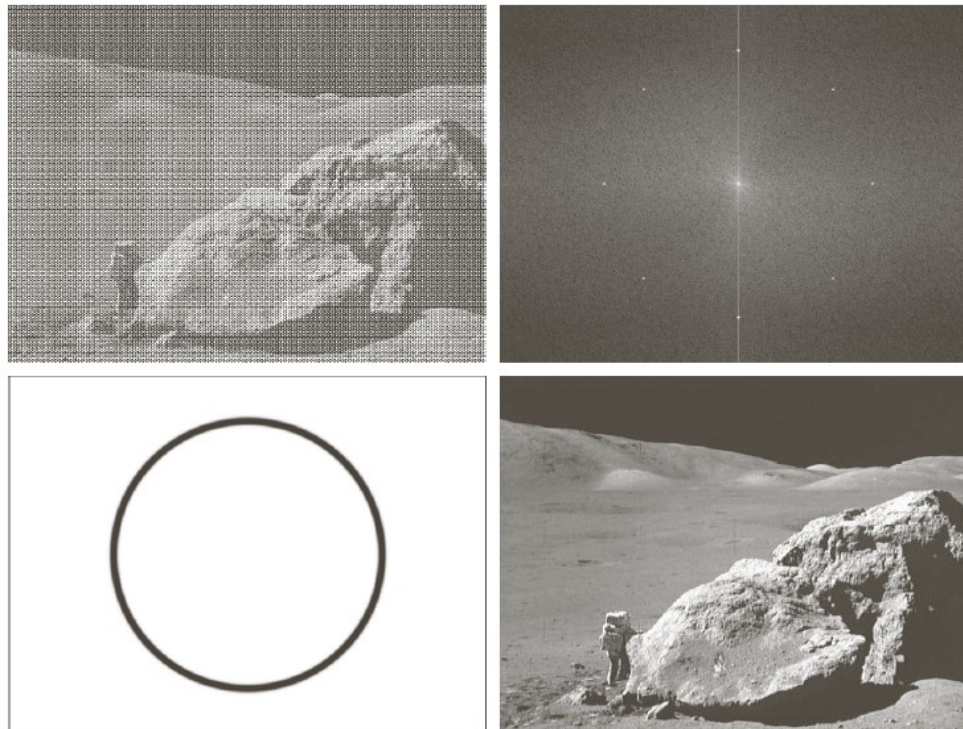

a b
c d

FIGURE 2.40

(a) Image corrupted by sinusoidal interference. (b) Magnitude of the Fourier transform showing the bursts of energy responsible for the interference. (c) Mask used to eliminate the energy bursts. (d) Result of computing the inverse of the modified Fourier transform. (Original image courtesy of NASA.)

a b
c d

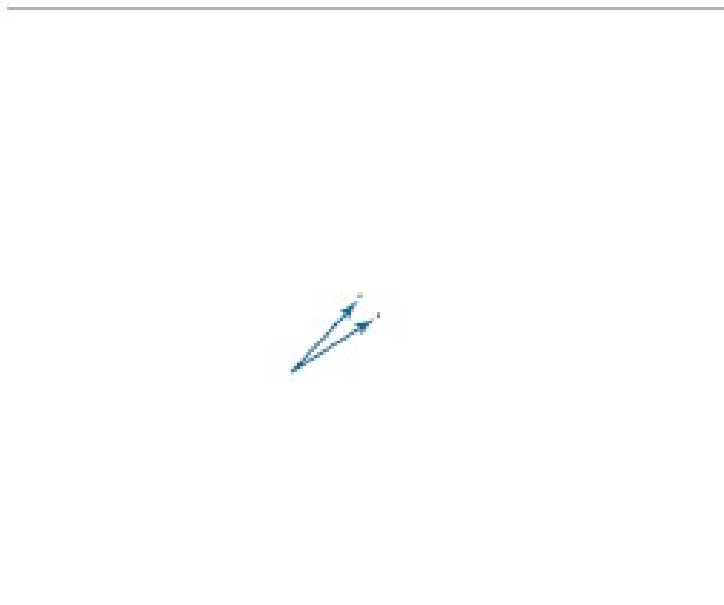
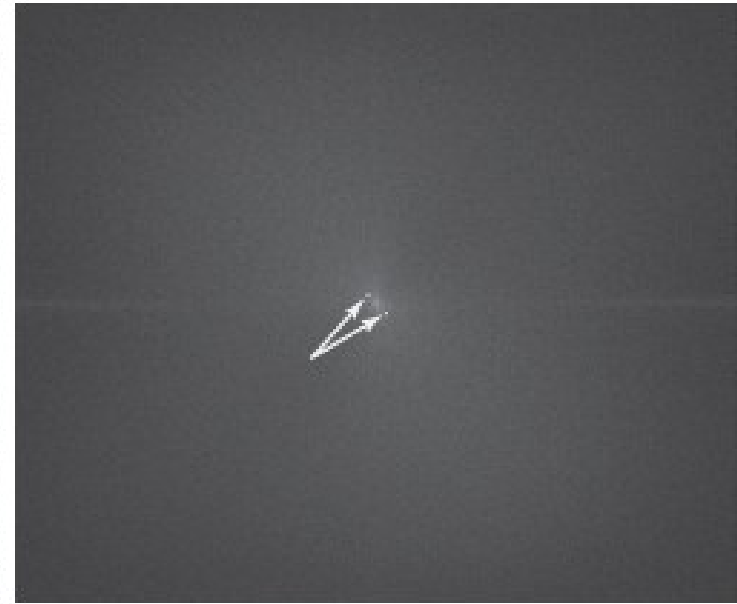
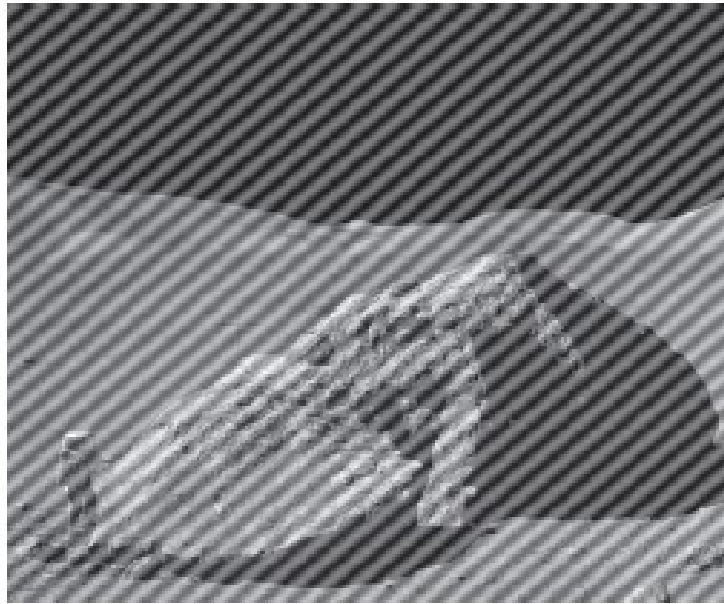
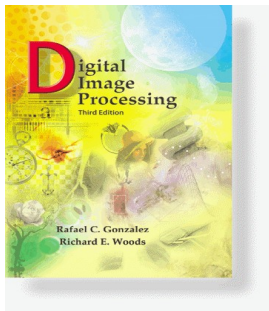

FIGURE 2.45
 (a) Image corrupted by sinusoidal interference.
 (b) Magnitude of the Fourier transform showing the bursts of energy caused by the interference (the bursts were enlarged for display purposes).
 (c) Mask used to eliminate the energy bursts.
 (d) Result of computing the inverse of the modified Fourier transform. (Original image courtesy of NASA.)



Digital Image Processing, 3rd ed.

Gonzalez &

Woods

www.dsp-processingPlace.com

Chapter 2

Digital Image Fundamentals

Probabilistic Models:

Let $z_i = 0, 1, 2, \dots, L-1$ ($L =$ Number of intensity levels)

$p(z_k) = \frac{n_k}{MN}$; $n_k =$ number of times z_k occurs in the image of size $M \times N$

Sum of the probabilities of intensities $= \sum_{k=0}^{L-1} p(z_k) = 1$

Mean intensity of an image $m = \sum_{k=0}^{L-1} z_k p(z_k)$

Variance $= \sigma^2 = \sum_{k=0}^{L-1} (z_k - m)^2 p(z_k)$

Nth moment of RV z (intensity) $= \mu_n(z) = \sum_{k=0}^{L-1} (z_k - m)^m p(z_k)$

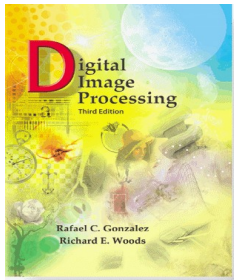

Digital Image Processing, 3rd ed.

Gonzalez &

Woods

www.ImageProcessingPlace.com

Chapter 2

Digital Image Fundamentals

Probabilistic models:

Image Processing: Probability of a single RV over a single 2D image

Stochastic Image Processing: Sequence of images & probability of intensity values

Random fields: Entire image to be a spatial random event

Standard Deviation (σ) = 14.3, 31.6, 49.2

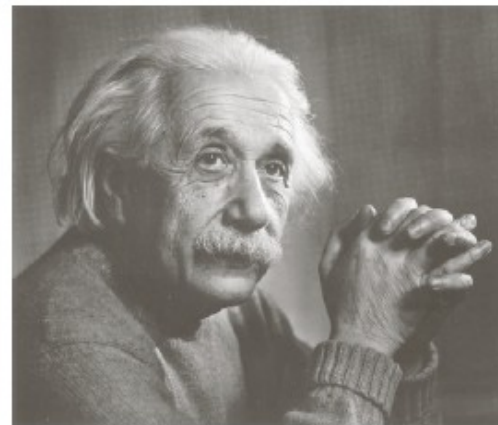
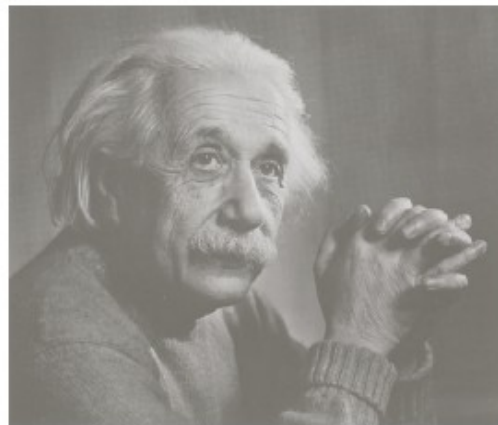
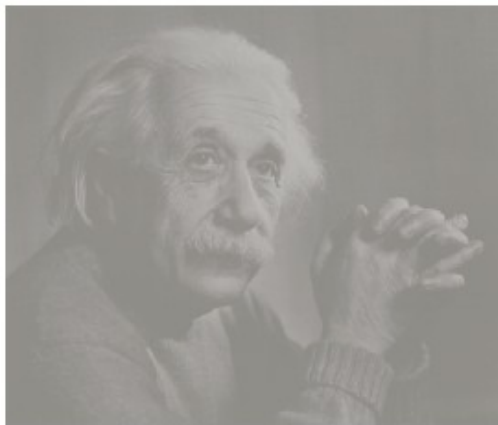

a b c

FIGURE 2.41

Images exhibiting (a) low contrast, (b) medium contrast, and (c) high contrast.