



# ARTIFICIAL INTELLIGENCE

## CS60045 Course Introduction

PROF. PALLAB DASGUPTA  
INDIAN INSTITUTE OF TECHNOLOGY KHARAGPUR  
[pallab@cse.iitkgp.ernet.in](mailto:pallab@cse.iitkgp.ernet.in)  
<http://cse.iitkgp.ac.in/~pallab>

# What is “Artificial Intelligence”?



## Turing Test (1950)

- The computer is interrogated by a human via a teletype.
- It passes if the human cannot tell if there is a computer or human at the other end

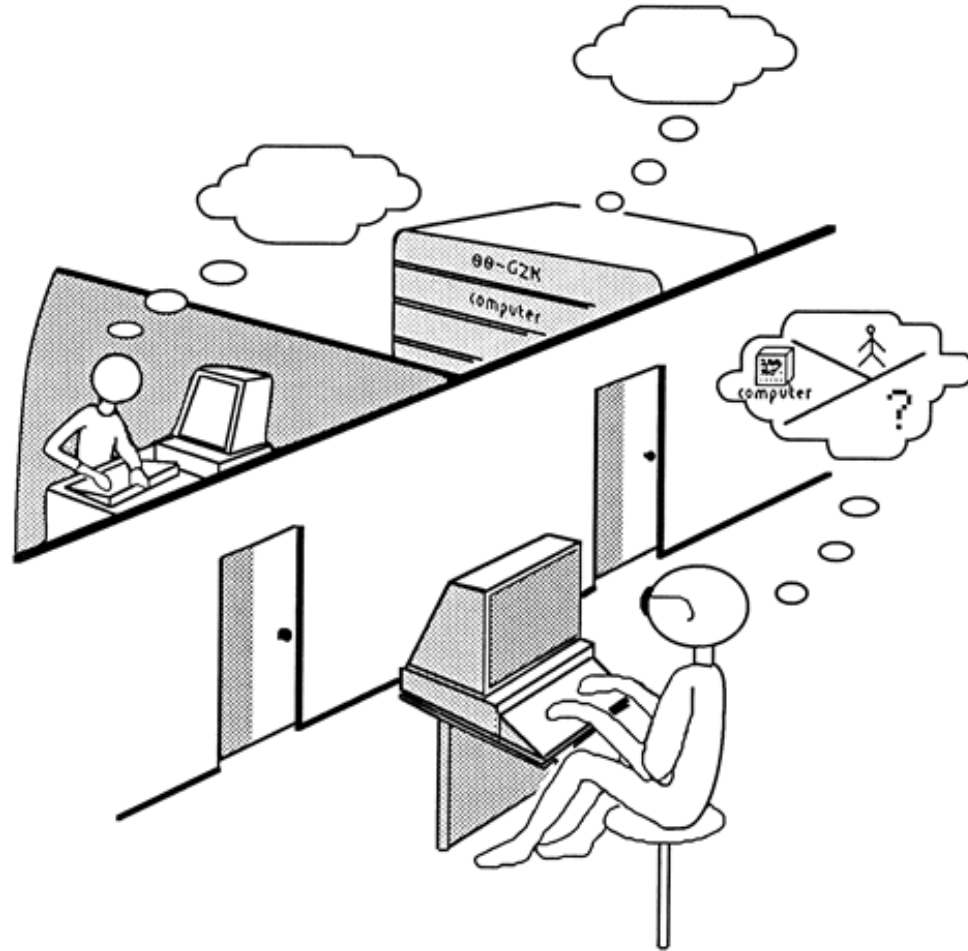

# What is Intelligence?

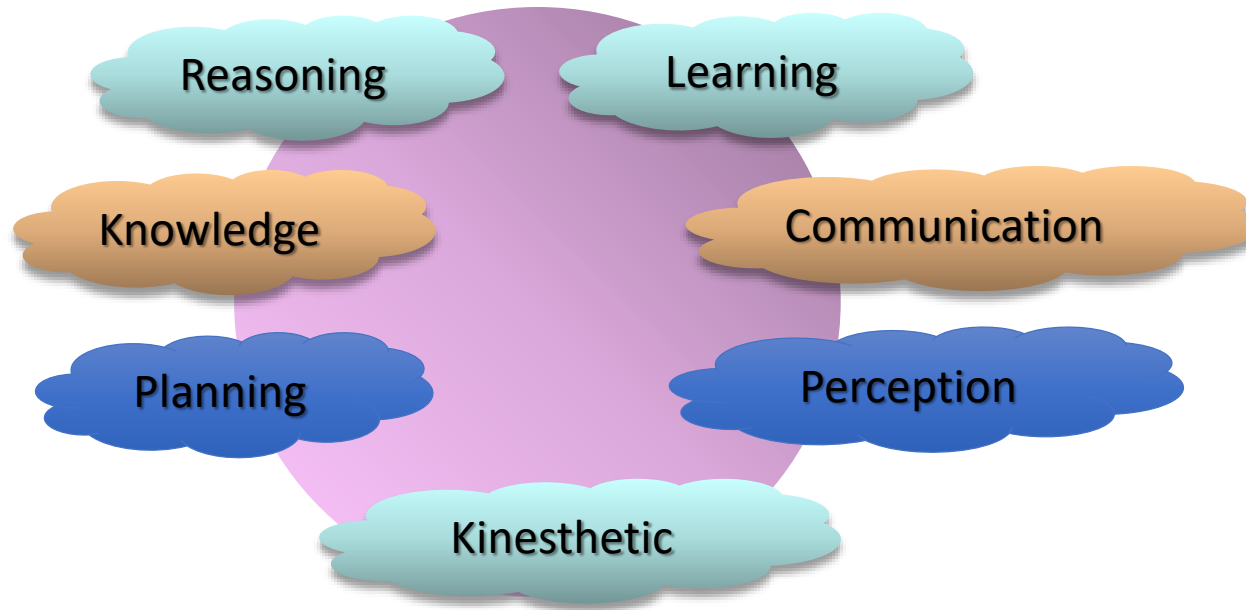

**Einstein's IQ = 160+**  
**What about yours ?**

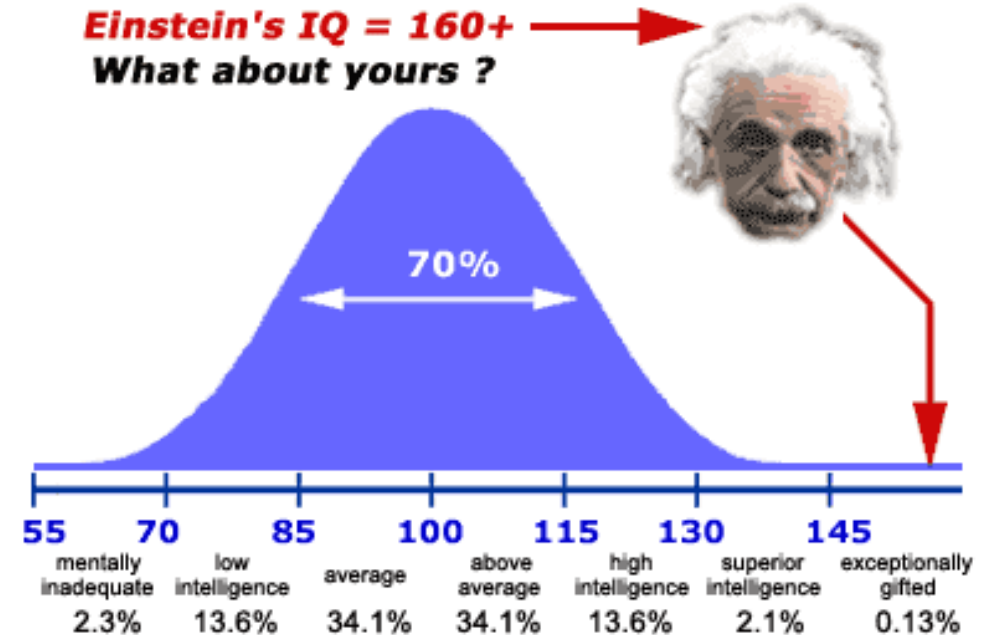



# Kasparov versus Deep Blue



On May 11, 1997, it won a 6-game match by 2 wins to 1 with 3 draws



Today, we have power to evaluate 200 million moves per second !!



# Evolution of AI

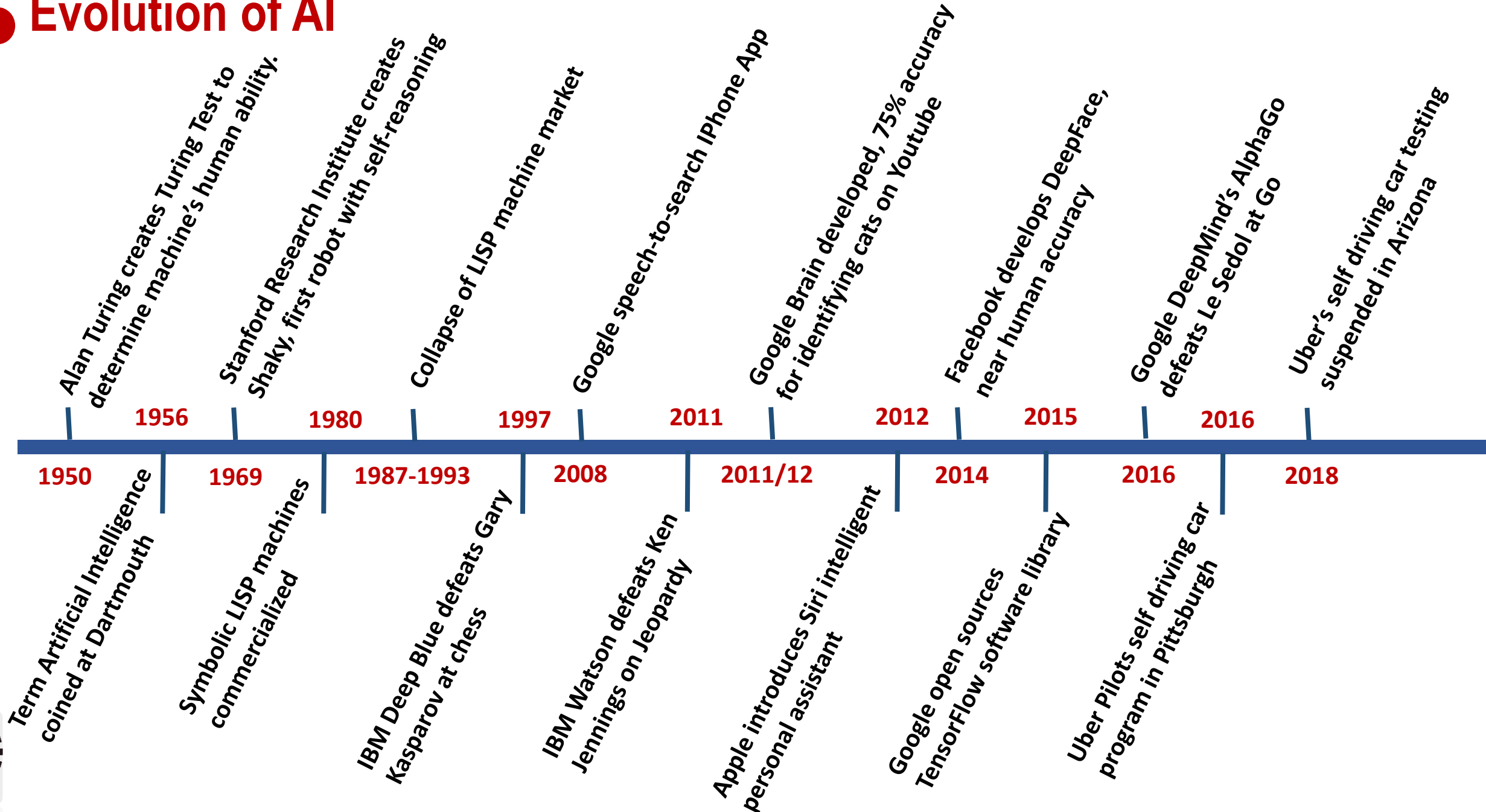

# Artificial Intelligence

## INTELLIGENT COMPUTATION

- **Automated Problem Solving**
  - Constraint satisfaction, Optimization, Search
- **Planning**
  - Abstraction
- **Automated Deduction**
  - Logic, Reasoning algorithms
- **Machine Learning**
  - Models, Data, Learning algorithms
- **Dealing with un-decidability and intractability**

## INTELLIGENT INTERFACE

- **Computer vision**
- **Speech and Natural Language Processing**
- **Robotics**

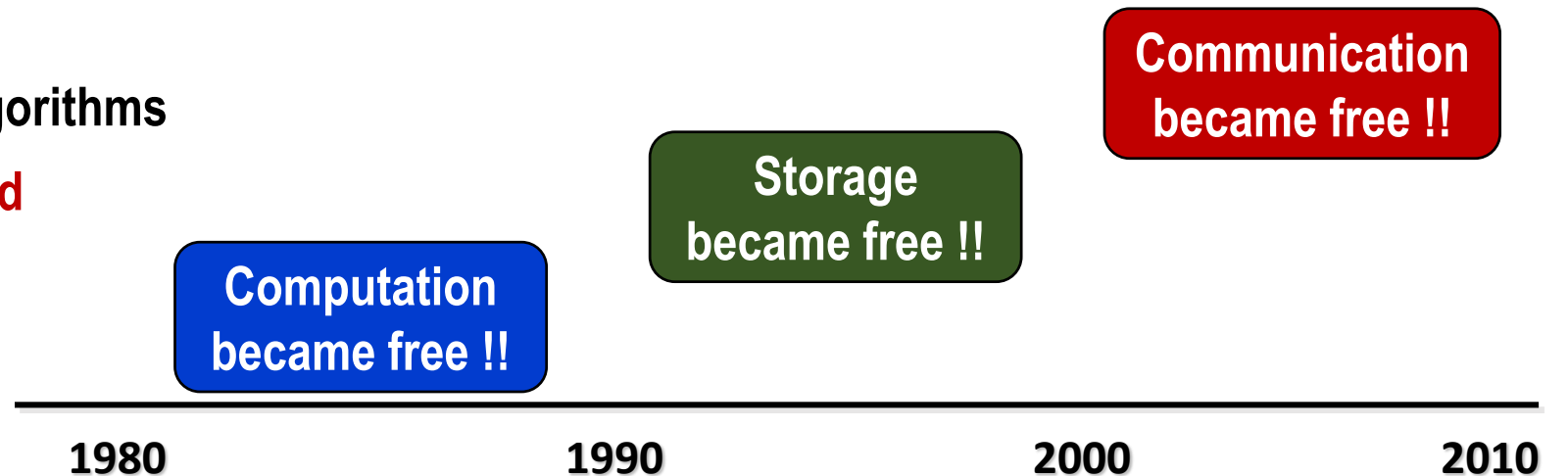

# Cyber-Physical Systems and Industrial Internet of Things

- ❑ Large number of computing elements
- ❑ Sensors everywhere
- ❑ Multitude of protocols

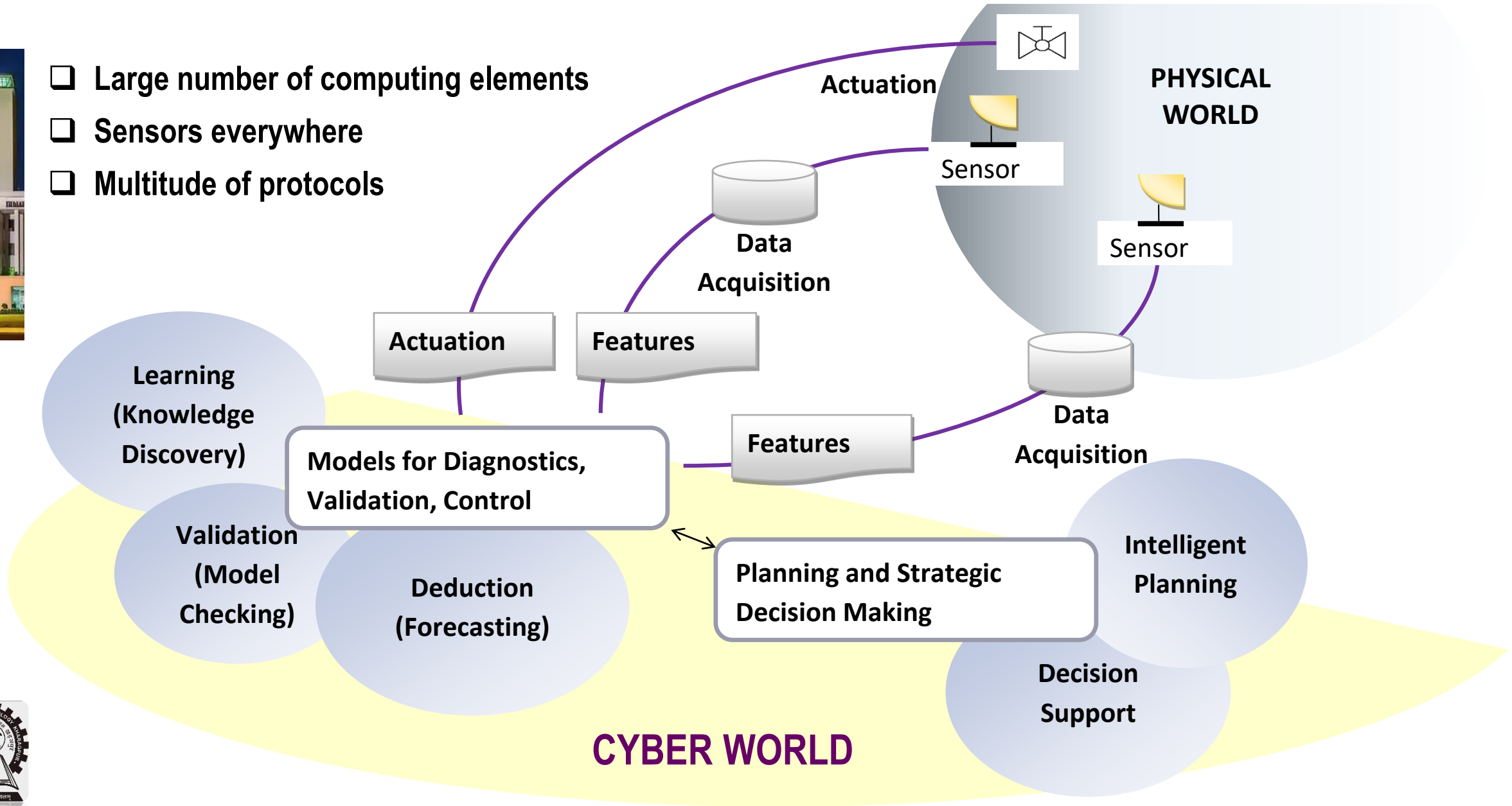



# Intelligent Machines

## Automotive control systems

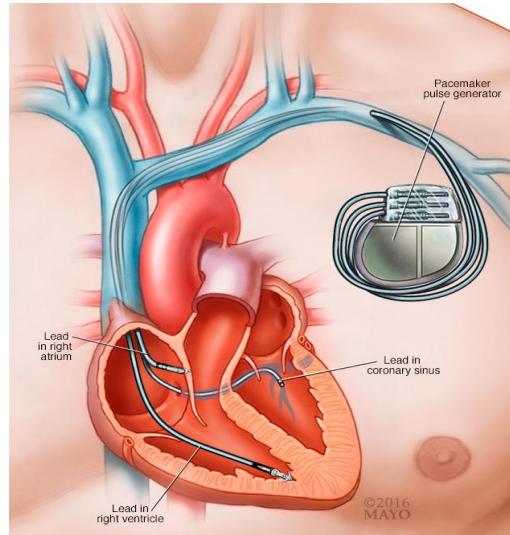
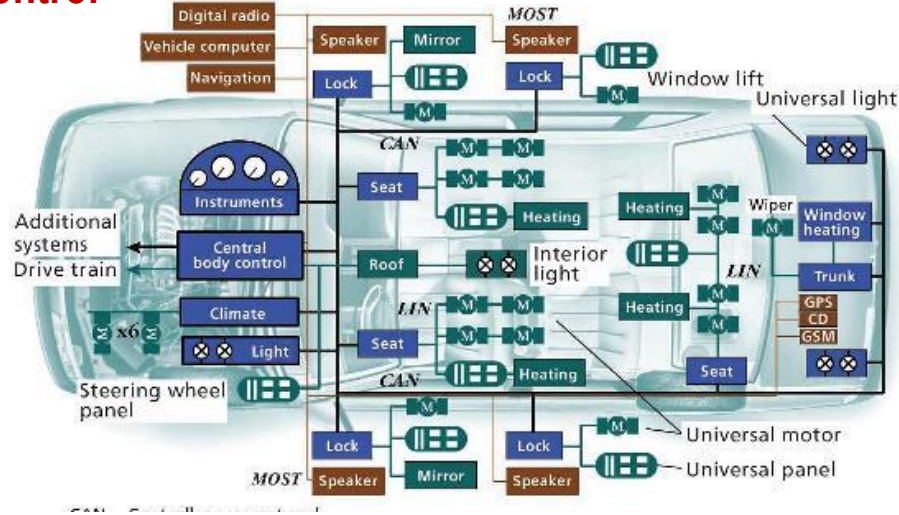

## Healthcare devices

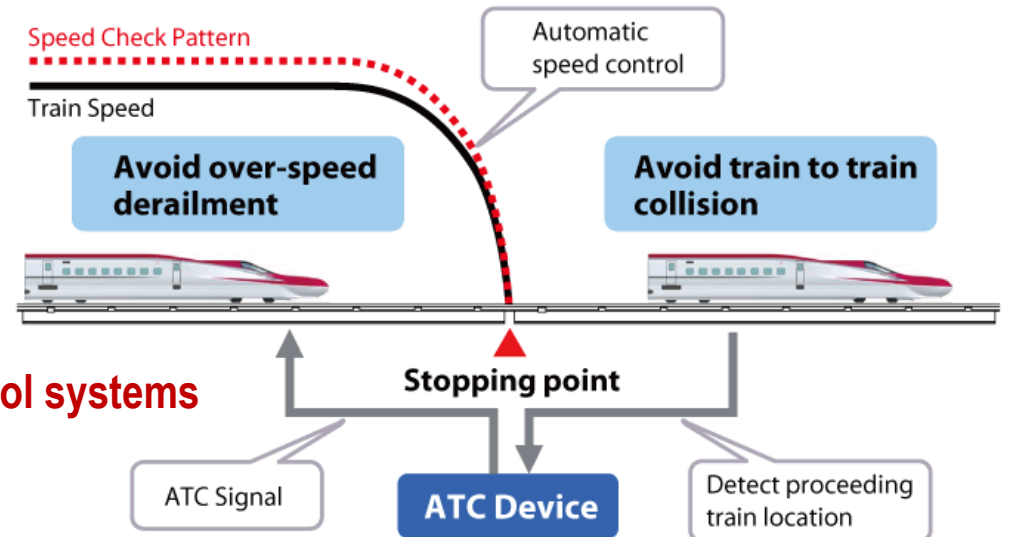
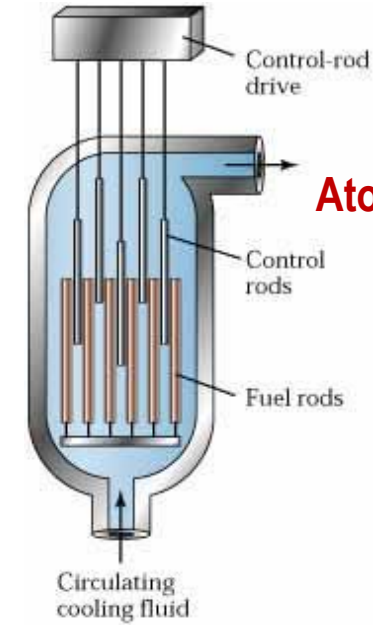

## Train control systems





# Digital Train

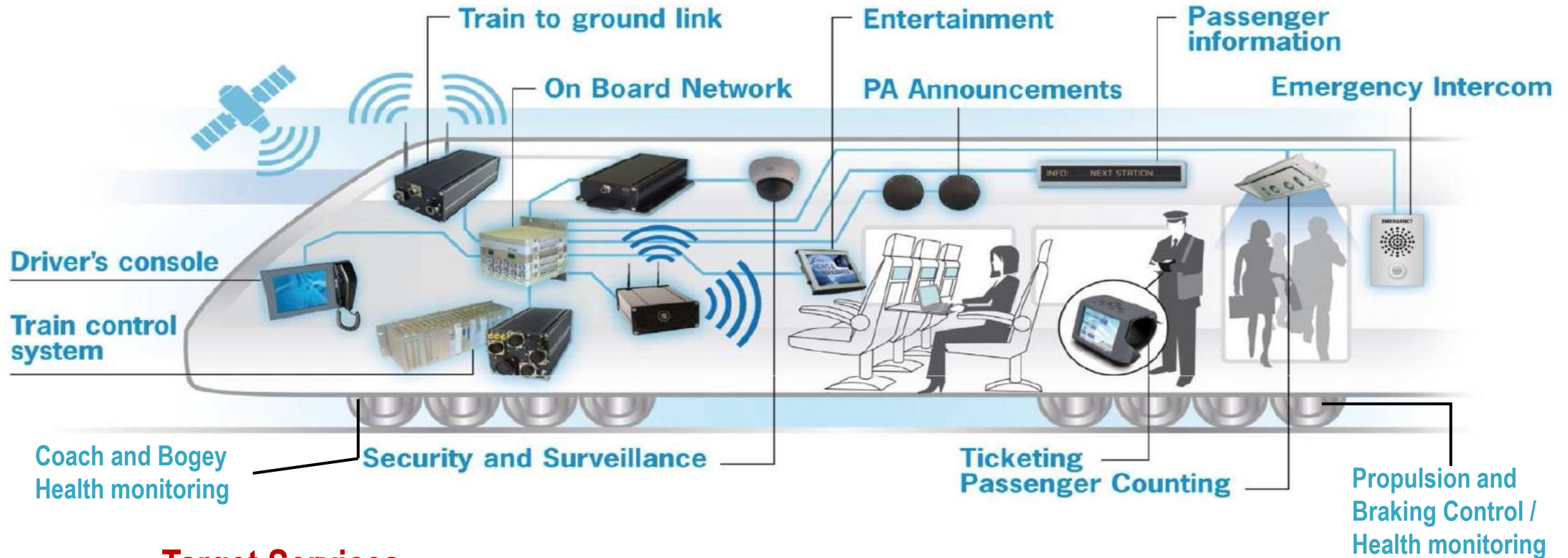

## Target Services

- Train control / localisation
- Health monitoring of structure, propulsion, braking systems
- Energy management
- Maintenance
- Security and surveillance
- Safety /Disaster management
- Signaling
- Infotainment
- Internet/Telephony



# AI in Smart Cities

- Intelligent and integrated transportation systems and traffic control
- Public safety (through intelligent surveillance and crowd sourced information)
- Urban infrastructure planning, construction, and maintenance
- Integrated health-monitoring
- Disaster Management
- Intelligent buildings (energy, safety, comfort)





# Would Emperor Shah Jahan have been benefitted if he had AI?





# 1. Sub-surface modeling for the foundation

Foundation of Taj Mahal

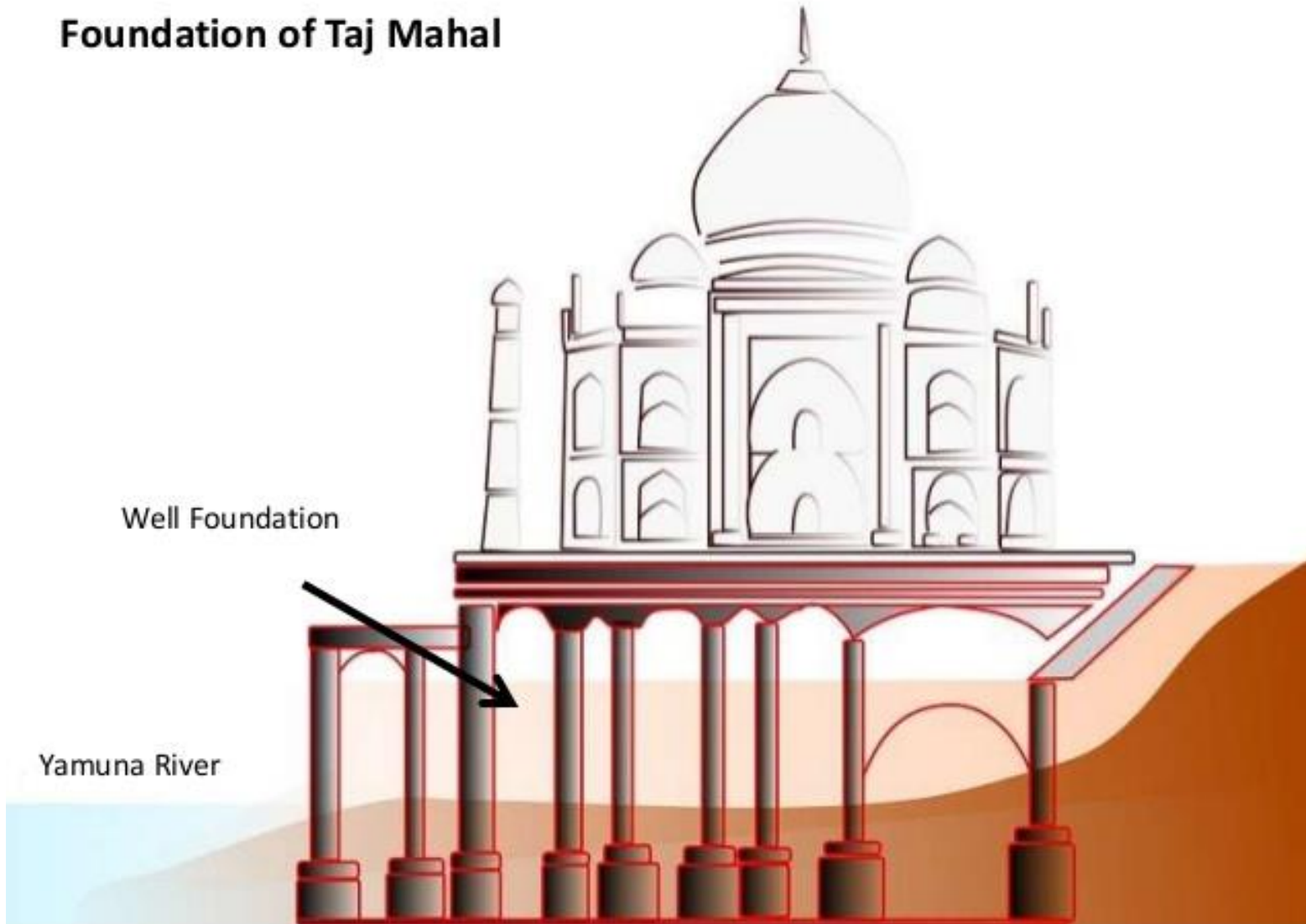

- How will the river shift?
- How much moisture may accumulate in the foundation?
- What kind of wood?
- How deep?
- How much and what kind of seismic protection?
- Deeply embedded sensors



## 2. Modeling the Minarets



**Petronas Towers, Kuala Lumpur**  
(towers appear to be tilted towards each other from a distance)

The Taj Mahal Minarets were designed to tilt outwards to create this optical illusion, as well as to guarantee that the minarets would fall outwards in case of an earthquake.

- The minarets are apparently tilting outwards every year
- What is the threat?



**Taj Mahal, Agra**  
(the minarets appear perfectly erect from a distance)



# 3. Predicting the effect of environment pollution

Before and after the mud-pack treatment

Now a health-monitoring set-up is in place to provide early warning of any pollutants





## 4. Business analytics to determine the feasibility of the black Taj



**Disclaimer:** The proposal for a black Taj may have been a myth according to some historians. However, if it indeed was planned, then it would have been way too expensive for the emperor. While the white marble came from Makrana, no black onyx seems to be available in India.



# Fundamentals

- ❑ The notion of expressing computation as an algorithm
- ❑ Godel's Incompleteness Theorem (1931):
  - In any language expressive enough to describe the properties of natural numbers, there are true statements that are undecidable: that is, their truth cannot be established by any algorithm.

# Fundamentals

- ❑ **Church-Turing Thesis (1936):**
  - **The Turing machine is capable of computing any computable function**
  - **This is the accepted definition of computability**
  
- ❑ **The notion of intractability**
  - **NP-completeness**
  - **Reduction**



# Course Outline

- Problem solving by search
- Logic and deduction
- Planning
- Reasoning under Uncertainty
- Learning
- Additional Topics and Applications

# References

- ❑ **Artificial Intelligence – A Modern Approach**  
**-- Stuart Russell and Peter Norvig**
- ❑ **Principles of Artificial Intelligence**  
**-- N J Nilsson**
- ❑ **Heuristics**  
**-- Judea Pearl**