

CS29002 SWITCHING LABORATORY
CSE Department, IIT Kharagpur
Spring Semester 2015–16
Module 5: Pulse circuits
Assignment 1
Date: 04–April–2016

The 555 timer IC chip is used to as a pulse generator and as an oscillator in electronic circuits. In this assignment, you experiment with two modes of operations of the 555 timer. The internal circuit diagram and the pin connections of the timer are given below.

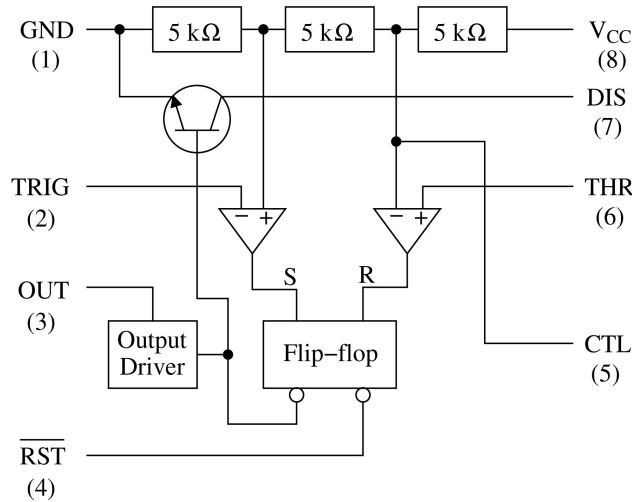

Part 1

An astable multivibrator (oscillator) can be built from the 555 timer using the following circuit.

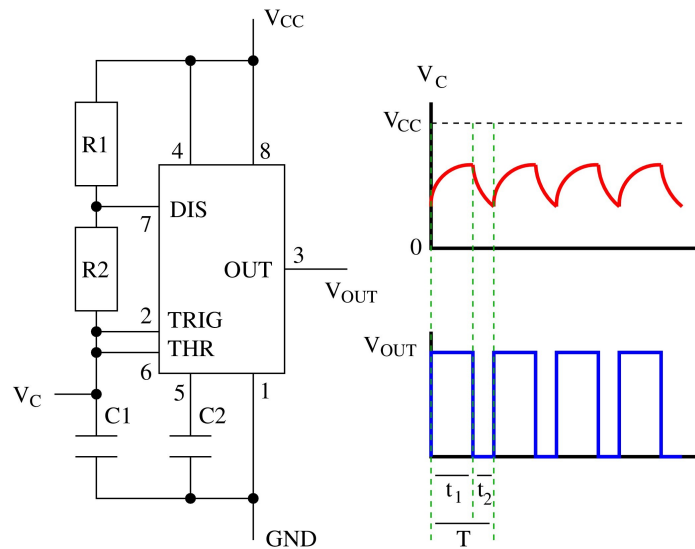

For this circuit, we have:

$$t_1 = 0.693 (R_1 + R_2) C,$$

$$t_2 = 0.693 R_2 C,$$

$$T = t_1 + t_2,$$

$$f = 1/T.$$

Design an astable multivibrator using a 555-timer chip to operate at 20 KHz frequency. Modify the circuit to get the maximum possible frequency.

Part 2

A negative-pulse-triggered monostable multivibrator can be designed using the 555 timer as follows.

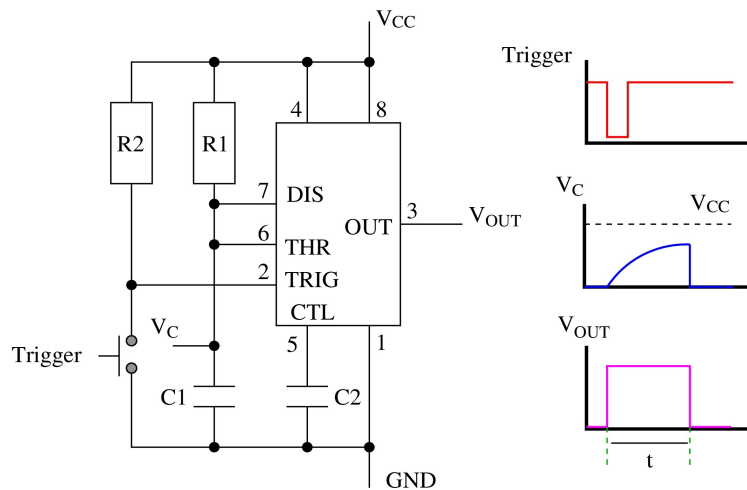

The width of the pulse created is $t = 1.1 R_1 C_1$.

Design a monostable multivibrator using a 555 timer chip for a positive pulse width of $100\mu\text{sec}$. Modify the circuit to get a 0.05 sec pulse width.

The monostable multivibrator requires a short trigger from a voltage above $V_{CC}/3$ to a voltage below $V_{CC}/3$. You cannot manually generate a trigger pulse of a short duration. Instead you use a differentiator circuit to produce the trigger pulses. To the input of the differentiator, you supply a square wave. During the falling edge of the square wave, the differentiator produces the desired negative trigger. The following circuit diagram illustrates this.

